

GB Premix gas burner

Modulating operation

WWW.SMARTFLAM.BY 
SmartFlam
Импортер
в Республику Беларусь
8 (029) 11 915 11 INFO@SMARTFLAM.BY

CODE	MODEL	TYPE
20139726	RX 150 S/PV	904T2



Translation of the original instructions

1	Declarations	3
2	Information and general warnings	4
2.1	Information about the instruction manual	4
2.1.1	Introduction	4
2.1.2	General dangers	4
2.1.3	Other symbols	4
2.1.4	Delivery of the system and the instruction manual	5
2.2	Guarantee and responsibility	5
3	Safety and prevention	6
3.1	Background	6
3.2	Personnel training	6
4	Technical description of the burner	7
4.1	Models available	7
4.2	Burner equipment	7
4.3	Technical data	8
4.4	Electrical data	8
4.5	Maximum dimensions	9
4.6	Burner description	10
4.7	Burner controls (LME71... with PME71.901...)	11
4.7.1	Indication of the diagnostic mode	16
5	Installation	17
5.1	Notes on safety for the installation	17
5.2	Handling	17
5.3	Preliminary checks	17
5.4	Operating position	18
5.5	Preparing the boiler	18
5.5.1	Boring the boiler plate	18
5.5.2	Head length	18
5.6	Position of probe and electrode (RX 150 S/PV)	19
5.7	Securing the burner to the boiler (RX 150 S/PV)	19
5.8	Fuel supply	20
5.9	Gas valve adjustment	21
5.10	Electrical wiring	22
6	Start-up, calibration and operation of the burner	23
6.1	Notes on safety for the first start-up	23
6.2	Adjustments prior to ignition	23
6.3	Fan adjustment	23
6.4	Burner start-up	24
6.4.1	First burner start-up (manual operation)	24
6.5	Manual Backup	27
6.5.1	Error during the backup procedure	27
6.6	Fan adjustment	28
6.7	Burner adjustment	28
6.7.1	Optimum calibration values	28
6.8	Combustion head	29
6.9	Setting and safety parameters (programmed control box)	29
6.10	Final checks (with burner operating)	30
7	Maintenance	31
7.1	Notes on safety for the maintenance	31
7.2	Maintenance programme	31
7.2.1	Maintenance frequency	31

7.2.2	Safety test - with gas feeding closed	31
7.2.3	Checking and cleaning.....	31
7.2.4	Safety components	33
7.3	Opening and closing the burner	33
7.4	Recommended preventive maintenance programme	34
8	Operation, indications, diagnostic	35
8.1	Control sequence in the event of a fault	35
8.2	Error code list with operation via the control box control panel.....	36
8.3	Resetting of burner control.....	37
8.3.1	Diagnostics of the cause of the fault	37
8.3.2	Before starting with a new program module or when the program module is replaced	38
8.4	Manual reset	39
8.4.1	Error during the reset process	40
8.4.2	Reset.....	40
A	List of parameters PME71.901...)	41
B	Appendix - Accessories	44
C	Appendix - Electrical panel layout.....	45

1 Declarations

Declaration of conformity in accordance with ISO / IEC 17050-1

Manufacturer:	RIELLO S.p.A.	
Address:	Via Pilade Riello, 7 37045 Legnago (VR)	
Product:	Pre-mixed gas burners	
Model and type:	RX 150 S/PV	904T2
These products are in compliance with the following Technical Standards:		
EN 12100		
EN 676		
and according to the European Directives:		
MD	2006/42/EC	Machine Directive
LVD	2014/35/UE	Low Voltage Directive
EMC	2014/30/UE	Electromagnetic Compatibility

Quality is ensured by means of an ISO 9001:2015 certified quality and management system.

Legnago, 01.12.2015

General Manager
RIELLO S.p.A. - Burners Department

Eng. U. Ferretti

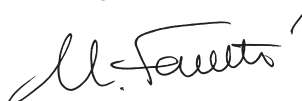

Research and Development Director
RIELLO S.p.A. - Burners Department

Eng. F. Comencini

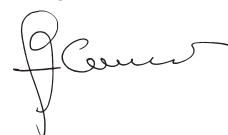

WWW.SMARTFLAM.BY 
SmartFlam

Импортер
в Республику Беларусь
8 (029) 11 915 11 INFO@SMARTFLAM.BY

2 Information and general warnings

2.1 Information about the instruction manual

2.1.1 Introduction

The instruction manual supplied with the burner:

- is an integral and essential part of the product and must not be separated from it; it must therefore be kept carefully for any necessary consultation and must accompany the burner even if it is transferred to another owner or user, or to another system. If the manual is lost or damaged, another copy must be requested from the Technical Assistance Centre of the area;
- is designed for use by qualified personnel;
- offers important indications and instructions relating to the installation safety, start-up, use and maintenance of the burner.

Symbols used in the manual

In some parts of the manual you will see triangular DANGER signs. Pay great attention to these, as they indicate a situation of potential danger.

2.1.2 General dangers

The **dangers** can be of **3 levels**, as indicated below.



Maximum danger level!
This symbol indicates operations which, if not carried out correctly, cause serious injury, death or long-term health risks.



This symbol indicates operations which, if not carried out correctly, may cause serious injury, death or long-term health risks.



This symbol indicates operations which, if not carried out correctly, may cause damage to the machine and/or injury to people.

2.1.3 Other symbols



DANGER: LIVE COMPONENTS
This symbol indicates operations which, if not carried out correctly, lead to electric shocks with lethal consequences.



DANGER: FLAMMABLE MATERIAL
This symbol indicates the presence of flammable materials.



DANGER: BURNING
This symbol indicates the risks of burns due to high temperatures.



DANGER: CRUSHING OF LIMBS
This symbol indicates the presence of moving parts: danger of crushing of limbs.



WARNING: MOVING PARTS
This symbol indicates that you must keep limbs away from moving mechanical parts; danger of crushing.



DANGER: EXPLOSION
This symbol signals places where an explosive atmosphere may be present. An explosive atmosphere is defined as a mixture - under atmospheric conditions - of air and flammable substances in the form of gases, vapours, mist or dust in which, after ignition has occurred, combustion spreads to the entire unburned mixture.



PERSONAL PROTECTION EQUIPMENT
These symbols indicate the equipment that must be worn and kept by the operator for protection against threats against safety and/or health while at work.



OBLIGATION TO ASSEMBLE THE COVER AND ALL THE SAFETY AND PROTECTION DEVICES
This symbol signals the obligation to reassemble the cover and all the safety and protection devices of the burner after any maintenance, cleaning or checking operations.



ENVIRONMENTAL PROTECTION
This symbol gives indications for the use of the machine with respect for the environment.



IMPORTANT INFORMATION
This symbol indicates important information that you must bear in mind.

- This symbol indicates a list.

Abbreviations used

Ch.	Chapter
Fig.	Figure
Page	Page
Sec.	Section
Tab.	Table

2.1.4 Delivery of the system and the instruction manual

When the system is delivered, it is important that:

- The instruction manual is delivered to the user by the system manufacturer, with the recommendation to keep it in the room where the heat generator is to be installed.
- The instruction manual shows:
 - the serial number of the burner;

.....

- the address and telephone number of the nearest Assistance Centre.

.....

- The system supplier must carefully inform the user about:
 - the use of the system;
 - any further tests that may be required before activating the system;
 - maintenance, and the need to have the system checked at least once a year by a representative of the manufacturer or another specialised technician.
 To ensure a periodic check, the manufacturer recommends the drawing up of a Maintenance Contract.

2.2 Guarantee and responsibility

The Manufacturer guarantees its new products from the date of installation, in accordance with the regulations in force and/or the sales contract. At the moment of the first start-up, check that the burner is integral and complete.



WARNING

Failure to observe the information given in this manual, operating negligence, incorrect installation and carrying out of non authorised modifications will result in the annulment by the manufacturer of the guarantee that it supplies with the burner.

In particular, the rights to the guarantee and the responsibility will no longer be valid, in the event of damage to things or injury to people, if such damage/injury was due to any of the following causes:

- incorrect installation, start-up, use and maintenance of the burner;
- improper, incorrect or unreasonable use of the burner;
- intervention of unqualified personnel;
- carrying out of unauthorised modifications on the appliance;
- use of the burner with safety devices that are faulty, incorrectly applied and/or not working;
- installation of untested supplementary components on the burner;
- powering of the burner with unsuitable fuels;
- faults in the fuel supply system;
- use of the burner even following an error and/or an irregularity;
- repairs and/or overhauls incorrectly carried out;
- modification of the combustion chamber with inserts that prevent the regular development of the structurally established flame;
- insufficient and inappropriate surveillance and care of those burner components most likely to be subject to wear and tear;
- use of non-original components, including spare parts, kits, accessories and optionals;
- force majeure.

The manufacturer furthermore declines any and every responsibility for the failure to observe the contents of this manual.

3 Safety and prevention

3.1 Background

The burners have been designed and built in compliance with current regulations and directives, applying the known technical rules of safety and envisaging all the potential danger situations.

It is necessary, however, to bear in mind that the imprudent and clumsy use of the equipment may lead to situations of death risk for the user or third parties, as well as the damaging of the burner or other items. Inattention, thoughtlessness and excessive confidence often cause accidents; the same applies to tiredness and sleepiness.

It is a good idea to remember the following:

- The burner must only be used as expressly described. Any other use should be considered improper and therefore dangerous.

Namely:

it can be applied to boilers operating with water, steam, diathermic oil, and to other uses expressly named by the manufacturer; the type and pressure of the fuel, the voltage and frequency of the electrical power supply, the minimum and maximum deliveries for

which the burner has been regulated, the pressurisation of the combustion chamber, the dimensions of the combustion chamber and the ambient temperature must all be within the values indicated in the instruction manual.

- Modification of the burner to alter its performance and destinations is not allowed.
- The burner must be used in exemplary technical safety conditions. Any disturbances that could compromise safety must be quickly eliminated.
- Opening or tampering with the burner components is not allowed, apart from the parts requiring maintenance.
- Only those parts envisaged by the manufacturer can be replaced.



The manufacturer guarantees safety and proper functioning only if all burner components are intact and positioned correctly.

3.2 Personnel training

The user is the person, body or company that has acquired the machine and intends to use it for the specific purpose. He is responsible for the machine and for the training of the people working around it.

The user:

- undertakes to entrust the machine exclusively to suitably trained and qualified personnel;
- undertakes to inform his personnel in a suitable way about the application and observance of the safety instructions. With that aim, the user undertakes to ensure that everyone knows the use and safety instructions for his own duties.
- Personnel must follow all the danger and caution indications shown on the machine.
- Personnel must not carry out, on their own initiative, operations or interventions that are not within their province.
- Personnel are obliged to inform their superiors of every problem or dangerous situation that may arise.
- The assembly of parts of other makes, or any modifications, can alter the characteristics of the machine and hence compromise operating safety. The manufacturer therefore accepts no responsibility whatsoever for any which may result from the use of non-original parts.

In addition:



- must take all the measures necessary to prevent unauthorised people gaining access to the machine;
- the user must inform the manufacturer if faults or malfunctioning of the accident prevention systems are noticed, along with any presumed danger situation;
- personnel must always use the personal protective equipment envisaged by legislation and follow the indications given in this manual.

4 Technical description of the burner

4.1 Models available

Designation	Voltage	Code	External modulation (*)
RX 150 S/PV	230V - 50-60 Hz	20139726	3 points

TC = Supplied combustion head

TL = Long combustion head version

(*) **FACTORY SETTING.** To change the external modulation parameter it is necessary to access the password-protected list of parameters using the AZL 21... display kit (page 44).

4.2 Burner equipment

- Gas valve flange + screws No. 1
- Insulating gasket No. 1
- 4 pin plug, 7 pin plug No. 1
- Screws and nuts for fixing the flange to the boiler No. 4
- Couplings and ring nuts for the passage of electrical wiring No. 1
- Instruction booklet No. 1
- Spare parts list No. 1

4.3 Technical data

Model			RX 150 S/PV
Type			904T4
Head assembly			Supplied with head assembled
Power ⁽¹⁾	min - max	kW	25-145
Delivery ⁽¹⁾	min - max	Mcal/h	21.5-124.7
Fuels			Natural gas: G20 (methane), G25 - LPG: (G31)(*)
Supply pressure ⁽²⁾		mbar	10-30
Gas valve input diameter			3/4 "
Operation			<ul style="list-style-type: none"> - Intermittent (min. 1 stop in 24 hours) - Modulating
Standard applications			Boilers: water, steam, diathermic oil
Ambient temperature		°C	0 - 55
Burner weight (without packaging)		kg	9

Tab. A

(1) Reference conditions: Ambient temperature 20°C - Gas temperature 15°C - Barometric pressure 1,013 mbar - Altitude 0 m a.s.l.

(2) Input valve gas pressure with zero pressure in the combustion chamber and at maximum burner output.

(*) **To operate with LPG just a different adjustment of the gas valve is required.**

4.4 Electrical data

Model			RX 150 S/PV
Type			-
Auxiliary circuit electrical supply			1N ~ 230V +/-10% 50/60 Hz
Electrical supply			1N ~ 230V +/-10% 50/60 Hz
Fan motor	rpm		8400
	V		230 V 50/60 Hz
	kW		0.24
	A		1.8
Ignition transformer	V1 - V2		230 V - 2 x 10 kV
	I1 - I2		0.3 A - 50/60 Hz 40 mA
Absorbed electric power	kW max		0,34
Protection level			IP 20

Tab. B

NOTE:

It is important to protect the burner with an external fuse (see wiring diagrams) to prevent the control getting damaged. The control box does not have a replaceable internal fuse.

4.5 Maximum dimensions

The maximum dimensions of the burner are given in Fig. 1.

Bear in mind that, in order to inspect the combustion head, the burner must be removed from the boiler door.

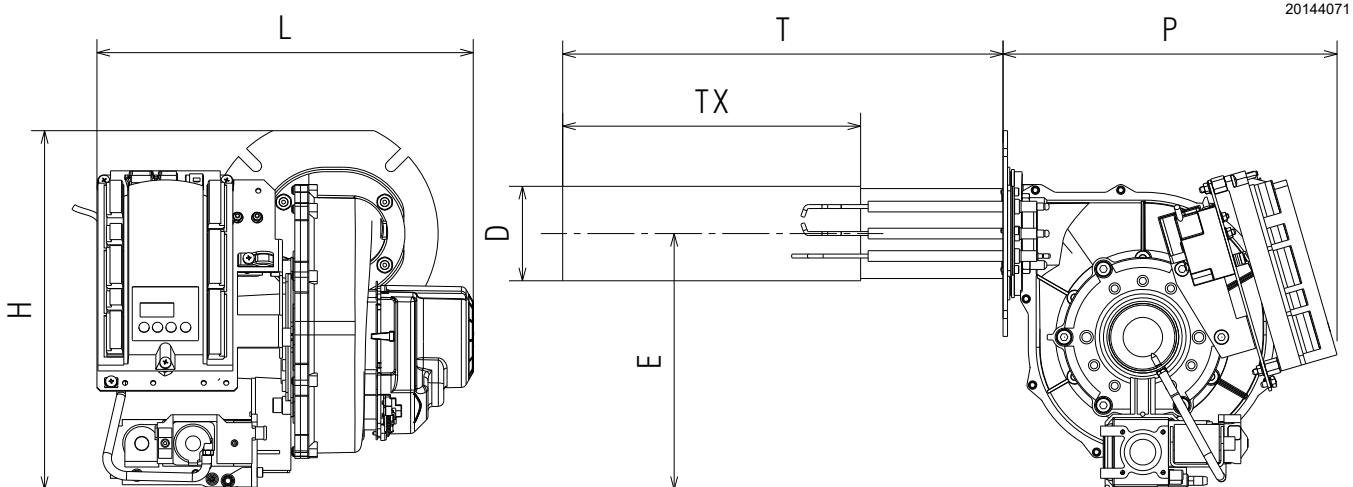

Fig. 1

mm	H	L	P	T	TX	D	E
RX 150 S/PV	320	335	297	392	265	84	228

Tab. C

mm	A	B	C
RX 150 S/PV	733	366	441

Tab. D

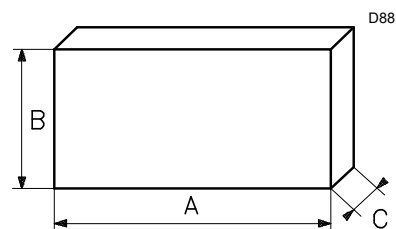

Fig. 2

4.6 Burner description

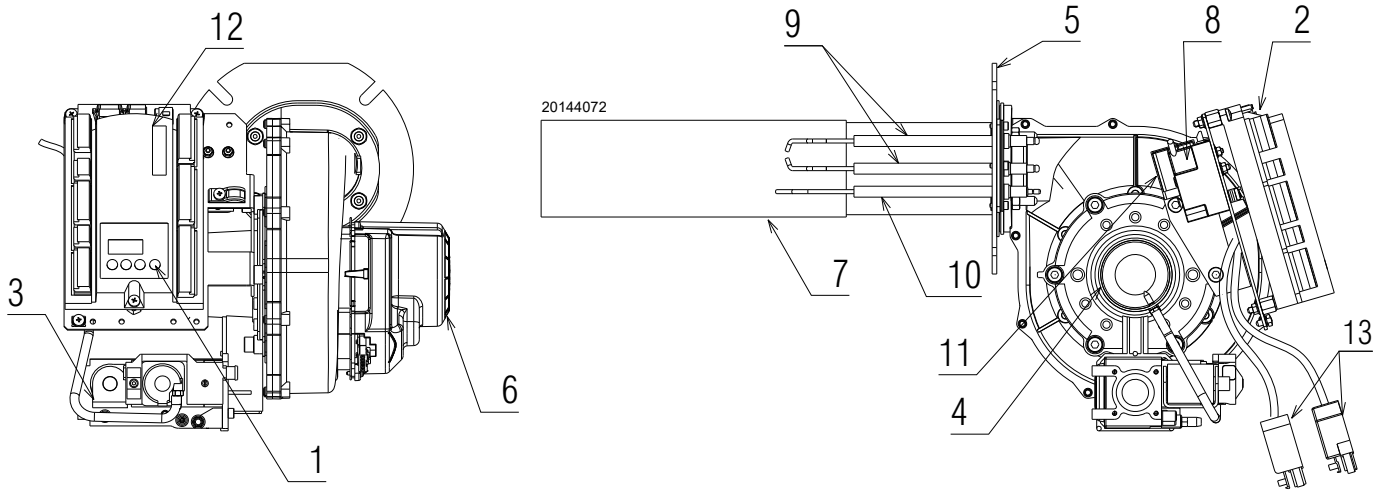

Fig. 3

- 1 Reset button
- 2 Control box
- 3 Gas valve
- 4 Air/gas mixer in intake circuit
- 5 Flange
- 6 Motor
- 7 Combustion head with metal mesh
- 8 Ignition transformer
- 9 Electrodes
- 10 Probe
- 11 Fan motor relay
- 12 Programming diagram
- 13 Sockets for electrical connection



Burner lockout may occur.

CONTROL BOX LOCKOUT:

The lockout signal is shown on the control box display with "LOC" and the error code. release by pressing the push-button 1)(Fig. 3).

4.7 Burner controls (LME71... with PME71.901...)

Warning



To avoid accidents, material or environmental damage, observe the following instructions!

The LME71... are safety devices! Avoid opening or modifying it, or forcing its operation.

Riello S.p.A. cannot assume any responsibility for damage resulting from unauthorised interventions! Also the safety notes contained in other chapters of this document must be respected!



The installation and operation of the machine should be carried out only by qualified personnel.

For the purposes of the safety notes in this document, by qualified personnel is meant people authorised to commission, ground and identify electric devices, systems circuits conforming to safety practices and norms.

- All the operations (assembly, installation, maintenance, etc.) should be carried out by qualified personnel.
- Before modifying the wiring in the connection area, fully disconnect the system from the power supply (omnipolar separation). Check the system is not powered and cannot be inadvertently restarted. Failure to do this will lead to the risk of electrocution.
- Ensure protection against the risks of electrocution by providing adequate protection at the terminal connection of the burner (for example, using blind terminals for the inputs and the unused outputs). Failure to do this will lead to the risk of electrocution.
- The space where the program module is placed (Fig. 5) is defined as a connection area and is therefore protected against accidental contact when the module is not present.
- If the housing or the area next to the operator panel is damaged, the unit should be immediately switched off. Failure to do this will lead to the risk of electrocution.
- Press the operator panel buttons only with your hands, without using any equipment or pointed objects. Damage to the operator panel fill leads to the risk of electrocution.

To ensure the safety and reliability of the LME71... system, the following instructions must also be followed:

- Avoid conditions which may promote condensation and humidity.
Otherwise, before switching on again, make sure that the entire control box is perfectly dry! Failure to do this will lead to the risk of electrocution.
- Static charges must be avoided since they can damage the control box's electronic components when touched.



The formation of condensation, ice and the infiltration of water must absolutely be avoided!

Otherwise, the safety functions could be compromise leading to a risk of electrocution.



S8593

Fig. 4

Program module



S8673

Fig. 5

Assembly notes

- Make sure that the relevant national safety standards are respected.
- The standard LME7 unit should be fixed with M4 (UNC32) or M5 (UNC24) fixing screws, respecting a maximum tightening torque of 1.8 Nm and using all 3 fixing points. The additional assembly surfaces of the housing have the purpose of improving the mechanical stability. The should rest on the assembly surface to which the unit is fixed. The planarity of the assembly surface should be within a tolerance range of 0.3 mm.

Installation notes

- Arrange the high voltage ignition cables separately, as far as possible from the control box and the other cables.
- Do not confuse the powered conductors with the neutral ones.
- Install the switches, fuses and grounding in compliance with local regulations.
- The connection diagrams show the burner controls with grounded neutral conductor.
- Make sure that the maximum admissible current of the terminal connections is not exceeded.
- Make sure the cable grommets of the connected cables comply with the relevant standards.
- Do not supply mains voltage to the control box outputs. During the testing of the devices controlled from the burner control (fuel valve, etc.), the LME71... should not be connected to the units.
- The mechanical connection between the actuators and the fuel and air control elements, or any other type, should be rigid.
- Make sure there are no short-circuits on the air pressure switch connection lines.

Electrical wiring to the flame detectors

It is important for signal transmission to be practically free of any disturbances or loss:

- Always separate the detector cables from the other cables:
 - the capacitive reactance of the line reduces the magnitude of the flame signal;
 - use a separate cable.
- Respect the permitted lengths for the cables of the detectors (see Technical Data).
- The ionisation probe powered from the mains is not protected from the risk of electric shocks.
- Position the ignition electrode and the ionisation probe so that the ignition spark cannot form an arc on the probe (risk of electric overload) and that it cannot negatively effect the supervision of the ionisation.

Description of displays and buttons

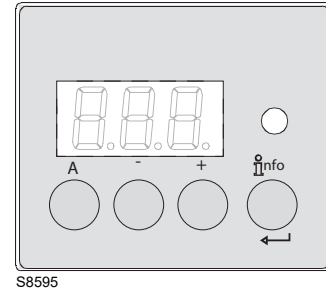

Fig. 6

Button	Function
	<p>Button A</p> <ul style="list-style-type: none"> – Displaying default output – In lockout position: output value at the time of the fault
	<p>Enter and Info button</p> <p>The reset button (info button) is the key element for resetting the burner control and activating/deactivating the diagnostic functions.</p>
	<p>Button -</p> <ul style="list-style-type: none"> – Displaying flame 2 signal current or displaying phases – In lockout position: MMI phase at the time of the fault
	<p>Button +</p> <ul style="list-style-type: none"> – Displaying flame 1 signal current or displaying phases – In lockout position: MMI phase at the time of the fault
	<p>Warning light with 3 colours</p> <p>The warning light with three colours (red - yellow - green) is the key indicator of the visual diagnostics.</p>
	<p>Button + and -: escape function</p> <p>Press the + and - buttons at the same time!</p> <ul style="list-style-type: none"> – No adoption of value – Access to a higher menu level – Keep pressed for >1 second for the backup/reset function

Tab. E

Technical data

Burner controls LME71...	Mains voltage	AC 230 V
	Mains frequency	50 / 60 Hz +/- 6%
	Power absorption	<10 W, normally
	Primary external fuse	Max. 6.3 A (slow)
	Safety class	I, with components in compliance with II and III, according to DIN EN 60730-1
"Input" terminals values	Voltage	UMains 230 V
	• If the mains voltage drops, there is a safety shut-down from the operating position	< AC 165 V
	• Restarting occurs when the mains voltage exceeds	> AC 195 V
	Input currents and voltages	
	– UeMax	UN +10%
	– UeMin	UN -15%
	– IeMax	peak 1 mA (peak value)
	– IeMin	peak 0.5 mA (peak value)
	Voltage detection	
	– ON	> AC 120 V
– OFF	< AC 80 V	
"Output" terminals Values	Total load on the contacts:	
	Nominal voltage	AC 230 V - 50/60 Hz
	Input current X3-04 unit (safety loop) from:	Max. 5A
	– fan motor contact maker	
	– ignition transformer	
	– fuel valves	
	Individual contact rating:	
	Fan motor contact maker X2-01 foot 3	
	– Nominal voltage	AC 230 V 50/60 Hz
	– Nominal current	2 A (15A max. 0.5 s)
	– Power factor	Cosφ ≥ 0.4
	Alarm output X2-03/3	
	– Nominal voltage	AC 230 V 50/60 Hz
	– Nominal current	1A
	– Power factor	Cosφ > 0.6
	Ignition transformer X4-02 foot 3	
	– Nominal voltage	AC 230 V 50/60 Hz
	– Nominal current	2A
	– Power factor	Cosφ > 0.4
	Auxiliary output	
	– Nominal voltage	AC 230 V 50/60 Hz
	– Nominal current	1A
	– Power factor	Cosφ > 0.6
	Output relay contact 2 foot 2 X2-09 foot 7	
	– Nominal voltage	AC 230 V 50/60 Hz
– Nominal current	1A	
– Power factor	Cosφ > 0.4	
Fuel valve/pilot valve X7-01 foot 3		
– Nominal voltage	AC 230 V 50/60 Hz	
– Nominal current	1A	
– Power factor	Cosφ > 0.4	
Safety valve X6-03 foot 3		
– Nominal voltage	AC 230 V 50/60 Hz	
– Nominal current	1.5 A	
– Power factor	Cosφ > 0.6	
Cable length	Power supply line from the mains	Max. 100m (100 pF/m)
Sections	The sections of the mains power supply lines (L, N, and PE) and, if necessary, the safety loop (safety limit thermostat, lack of water, etc.) should be sized for the nominal currents according to the external primary fuse selected. The sections of the other cables should be sized based on the fuse of the internal unit (max. 6.3 AT).	
Environmental conditions	Operation	DIN EN 60721-3-3
	Climatic conditions	Class 3K3
	Mechanical conditions	Class 3M2
	Temperature range	-40...+60°C
	Humidity	< 95% RH

Tab. F



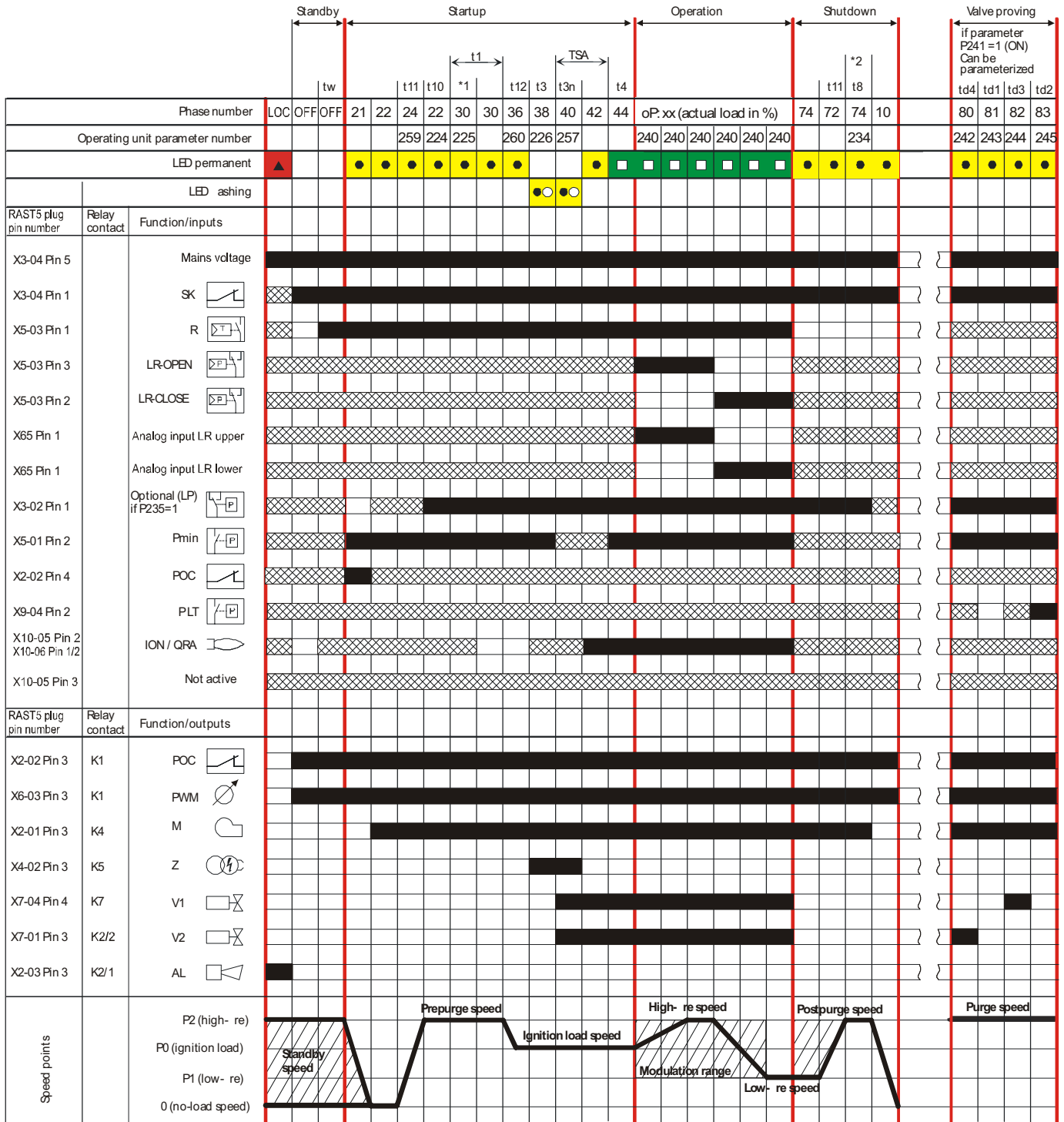

Program sequence



S8594

Fig. 7

Key Fig. 7:

AL	Alarm device
AUX	Auxiliary output
Dbr	Lead connection
 (EK1)	Reset button (info button)
EK2	Remote reset button
FSV	Flame signal amplifier
ION	Ionisation probe
K...	Relay contact
LED	Warning light with 3 colours
LP	Air pressure switch
LR	Load controller
LR-OPEN	Load controller OPEN
LR-CLOSE	Load controller CLOSED
M	Fan motor
NT	Power supply unit
P LT	Pressure switch valve test
Pmax	Max. pressure switch
Pmin	Min. pressure switch
POC	Closure test
PV	Pilot valve
QRA...	UV flame detector
R	Control thermostat or pressure switch
SA	Actuator
SA-KL	Low flame actuator
SA-NL	High flame actuator
SA-R	Feedback actuator
SA-Z	Actuator CLOSED
SA-ZL	Ignition load actuator
SL	Safety loop
STB	Safety limit thermostat
SV	Safety valve
V1	Fuel valve
V2	Fuel valve
V2a	Fuel valve
W	Limit pressure switch or thermostat
Z	Ignition transformer
µC	µC controller
	Input/output 1 signal (ON)
	Input/output 2 signal (ON)
	Input 1 permitted signal (ON) or 0 (OFF)

Tab. G

Times

TSA	Safety time
tw	Standby time
t1	Pre-purging time
t3	Spark pre-ignition time
t3n	Post-ignition time (P257 +0.3 seconds)
t4 (depending on the application)	Interval: end of safety time - fuel valve 1 ON Interval: end of safety time - fuel valve 2 ON Interval: end of safety time - load controller reset
t5	Interval: Pilot valve OFF - load controller reset
t8	Post-purging time
t9 (depending on the application)	Interval: Fuel valve 1 ON - pilot valve OFF Interval: Fuel valve 2 ON - pilot valve OFF
t10	Time specified for air pressure switch status message (timeout)
t11	Actuator opening time (timeout)
t12	Actuator closing time (timeout)
t22	2nd safety time
td1	Air pressure test
td2	Gas pressure test
td3	Gas valve filling test
td4	Gas valve bleed test

Tab. H

Phases key (Fig. 7 on page 14):

Phase number	Function
LOC	Switching off phase lockout
OFF	Stand-by, awaiting heat request
oP	Part 1: Load controller request OPEN
	Part 2: fan motor modulation speed towards high flame
	Part 3: high flame reached
	Part 4: load controller request CLOSED
	Part 5: fan motor modulation speed towards low flame
	Part 6: low flame reached
10	Settling time, fan motor standby speed
21	Safety valve ON, air pressure switch in load absence position
	Check that the POC is closed and that the fan motor speed has been reduced to 0
22	Part 1: fan motor ON
	Part 2: specified time air pressure switch Message (timeout), air pressure switch stabilisation
24	Settling time, fan motor pre-purging speed
30	Part 1: pre-purging time without flame simulation test
	Part 2: pre-purging time with flame simulation test (2.1 seconds)
36	Stabilisation time at ignition speed
38	Spark pre-ignition time
40	Post-ignition time, parameter 257 + 0.3 seconds
42	Flame detection
44	Interval: end of time for safety ignition and load controller reset (modulation start)
72	Settling time speed, fan motor post-purging speed
74	Part 1: the operation is finished, check that the post-purging has been programmed
	Part 2: post-purging time
Only with leak detection control	
80	The test space is empty
81	Air pressure test
82	The test space is full
83	Gas pressure test
90	Min pressure switch open--> switching off safely
*1	Test valve, if P241 = 1 after each ON, lockout or P234 (post-purging time) = 0 seconds
*2	Test valve, if P241 = 1 and P234 (post-purging time) >0 seconds

Tab. I

4.7.1 Indication of the diagnostic mode



The reset button (info button) is the key element for resetting the burner control and activating/deactivating the diagnostic functions.



The multi-colour indicator lamp is the key indicator of the visual diagnostics.

Both the reset button and the indicator lamp are on the control panel.

There are 2 diagnostic options:

- 1 Visual diagnostics: Indication of the operating status or diagnostics of the cause of the fault
- 2 Diagnostics: From BCI to AZL2... operating and display unit

Visual diagnostics:

During normal operation, the various operating conditions are shown in the form of colour codes based on the table shown below (Tab. J).

Indication of the operating status

During start-up, the status indication is based on Tab. J:

Table of colour codes for multi-colour indicator lamp

Status	Colour code	Colour
Standby time, other waiting modes	○.....	OFF
Ignition phase, controlled ignition	●○●○●○●○	Blink yellow
Operation, flame o.k.	■.....	Green
Operation, flame not o.k.	■○■○■○■○	Green blink
Burner start-up extraneous light	■▲■▲■▲■▲	Green-Red
Undervoltage	●▲●▲●▲●▲	Yellow - Red
Fault, alarm	▲.....	Red
Output error code (see error code Tab. Y on page 37)	▲○▲○▲○▲○	Red blinking
Diagnostics interface	▲▲▲▲▲▲▲▲	Red blinking light
Heat request	●.....	Yellow
New program board	●●▲●●▲●●	Yellow - Red

Tab. J

Key to layout (Tab. J)

- Always on
- OFF
- ▲ Red
- Yellow
- Green

5 Installation

5.1 Notes on safety for the installation

After carefully cleaning all around the area where the burner is to be installed, and arranging for the environment to be illuminated correctly, proceed with the installation operations.



All the installation, maintenance and disassembly operations must be carried out with the electricity supply disconnected.



The installation of the burner must be carried out by qualified personnel, as indicated in this manual and in compliance with the standards and regulations of the laws in force.



Combustion air inside the boiler must be free from hazardous mixes (e.g.: chloride, fluoride, halogen); if present, it is highly recommended to carry out cleaning and maintenance more frequently.

5.2 Handling

The packaging of the burner includes a wooden platform, so it is possible to move the burner (still packaged) with a transpallet truck or fork lift truck.



The handling operations for the burner can be highly dangerous if not carried out with the greatest attention: keep any unauthorised people at a distance; check the integrity and suitability of the available means of handling. Check also that the area in which you are working is empty and that there is an adequate escape area (i.e. a free, safe area to which you can quickly move if the burner should fall). When handling, keep the load at not more than 20-25 cm from the ground.



After positioning the burner near the installation point, correctly dispose of all residual packaging, separating the various types of material.



Before proceeding with the installation operations, carefully clean all around the area where the burner will be installed.

5.3 Preliminary checks

Checking the consignment



After removing all the packaging, check the integrity of the contents. In the event of doubt, do not use the burner; contact the supplier.



The packaging elements (wooden cage or cardboard box, nails, clips, plastic bags, etc.) must not be abandoned as they are potential sources of danger and pollution; they should be collected and disposed of in the appropriate places.

Checking the characteristics of the burner

Check the burner identification label (Fig. 8), showing:

- model **A**) and the type of burner **B**);
- the year of manufacture, in cryptographic form **C**);
- the serial number **D**);
- the electrical supply data **E**);
- the electrical power consumption **F**);
- the types of fuel used and the relative supply pressures **G**);
- the possible minimum and maximum output data of the burner **H**) (see Firing rate);
- maximum absorbed current **I**);
- burner weight **L**).

R.B.L.	A		B	C
D		E		F
II 2R 3R	GAS	<input type="checkbox"/> G	H	
	GAZ	<input type="checkbox"/> G	H	
RIELLO S.p.A. / I-37045 Legnago (VR) cod. xxxxxxxx		I	L	CE

20122363

Fig. 8



The burner output must be within the boiler's firing rate;



A burner label, or any other component, that has been tampered with, removed or is missing, prevents the definite identification of the burner and makes any installation or maintenance work difficult

5.4 Operating position



The burner is designed to work only in the positions **1, 2, 3, 4 and 5**.

Installation **1** is preferable, as it is the only one that allows the maintenance operations as described in this manual.

Installations **2, 3, 4 and 5** allow it to operate but make maintenance operations more difficult (Fig. 9).



Any other position could compromise the correct operation of the appliance.

All the positions require the installation of the gas valve with coils facing upwards or horizontally. Installation with the coils facing downwards is absolutely forbidden **6**.

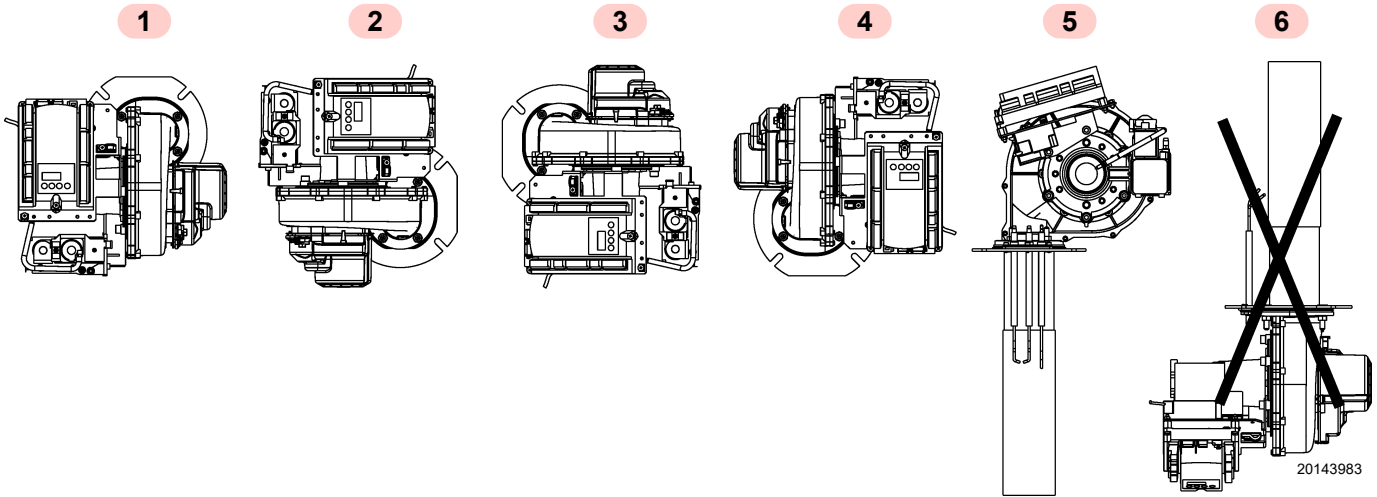

Fig. 9

5.5 Preparing the boiler

5.5.1 Boring the boiler plate

Pierce the closing plate of the combustion chamber, as in Fig. 10. The position of the threaded holes can be marked using the thermal insulation screen supplied with the burner.

mm	D1	W1	R	W6
RX 150 S/PV	145	170	10	45°

Tab. K

5.5.2 Head length

The length of the head must be selected according to the indications provided by the manufacturer of the boiler, and in any case the combustion area must be greater than the thickness of the boiler door complete with refractory.



The burners cannot be used on flame inversion boilers.

It is possible to insert a protective device made of refractory material between the combustion head and the boiler refractory. This protection must allow the blast tube to be taken out.



Do not insert the protection in line with the electrode unit, as this would compromise its good operation.

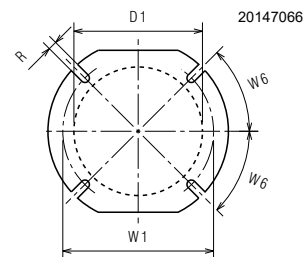

Fig. 10

5.6 Position of probe and electrode (RX 150 S/PV)



Before installing the burner on the boiler, make sure the probe and electrode have been positioned correctly as in Fig. 11.

Do not turn the electrode, position it as shown in Fig. 11. Placing the electrode near the ionisation probe may result in the control box amplifier being damaged.

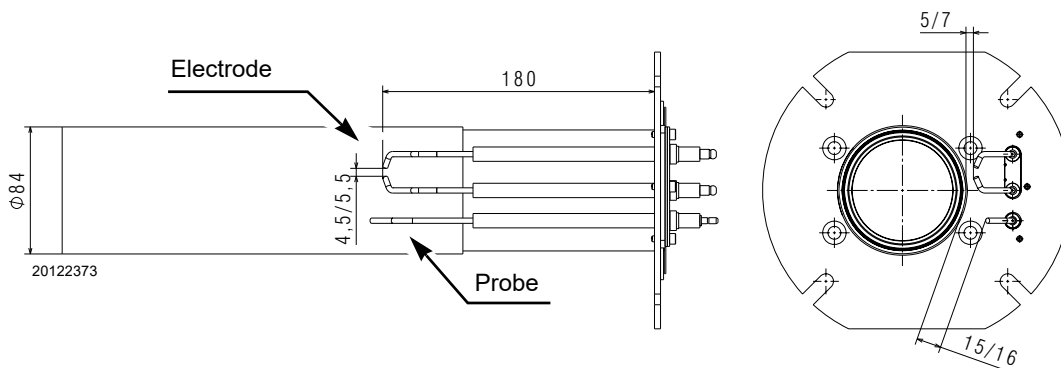

Fig. 11

5.7 Securing the burner to the boiler (RX 150 S/PV)

For the installation proceed as follows:

- Fix the burner 1) to the door of the boiler 2) putting the insulating gasket 3) in between (Fig. 12).



During this operation, take care not to touch the electrode unit.

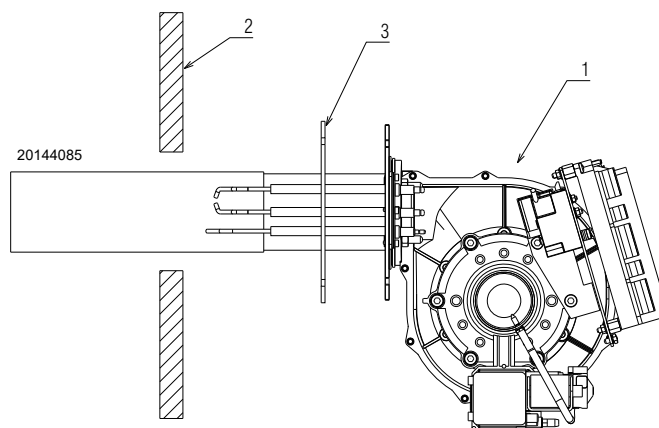

Fig. 12

5.8 Fuel supply



Explosion danger due to fuel leaks in the presence of a flammable source.

Precautions: avoid knocking, attrition, sparks and heat.

Make sure the fuel interception tap is closed before performing any operation on the burner.



WARNING

The fuel supply line must be installed by qualified personnel, in compliance with current standards and laws.



DANGER

Disconnect the electrical power using the main switch.



Check that there are no gas leaks.



Pay attention when handling the train: danger of crushing of limbs.



Make sure that the gas train is properly installed by checking for any fuel leaks.



WARNING

Refer to the accompanying instructions for the adjustment of the gas train.



The operator must use the required equipment during installation.

The burners are teamed with one-piece pneumatic proportioning gas valves, via which the amount of gas delivered, and hence the output produced, can be modulated.

A signal reporting pressure detected in the air circuit is carried to the pneumatic gas valve, which delivers an amount of gas in proportion to the airflow produced by the fan.

To optimise the bulk, the gas train is assembled directly on the body of the burner.

Air/gas mixer Fig. 13

Gas and combustive air are mixed inside the purging circuit (mixer), starting from the intake inlet.

Through the gas train, fuel is introduced into the intake air current and optimal mixing commences with the aid of a mixer.

Gas valve

Valve model	Honeywell VR4615VB1006 B
Mixer model	Honeywell 45900450-0301 B
Gas line connection	3/4" input
Working temperature	-15°C/70°C
Max. working pressure	30 mbar
Min. working pressure	15 mbar
Max. inlet pressure	60 mbar
Valve class	B + C
Electrical supply	220-240 V
Protection level	IP 40 according to IEC 529

Tab. L



Импортер
в Республику Беларусь
8 (029) 11 915 11 INFO@SMARTFLAM.BY

5.9 Gas valve adjustment

The adjustment of the gas flow rate is carried out using the two screws V1 and V2.

To alter the maximum output of gas act on the screw V1.

- To increase the output: turn the screw V1 anticlockwise (unscrew).
- To reduce the output: turn the screw clockwise (tighten)
- To alter the minimum output of gas act on the screw V2 on the gas valve.

Remove the protection screw and act on the intern screws with a hex key.

- To increase the output: turn the screw clockwise (tighten).
- To reduce the output: turn the screw anticlockwise (unscrew).

Gas train assembly

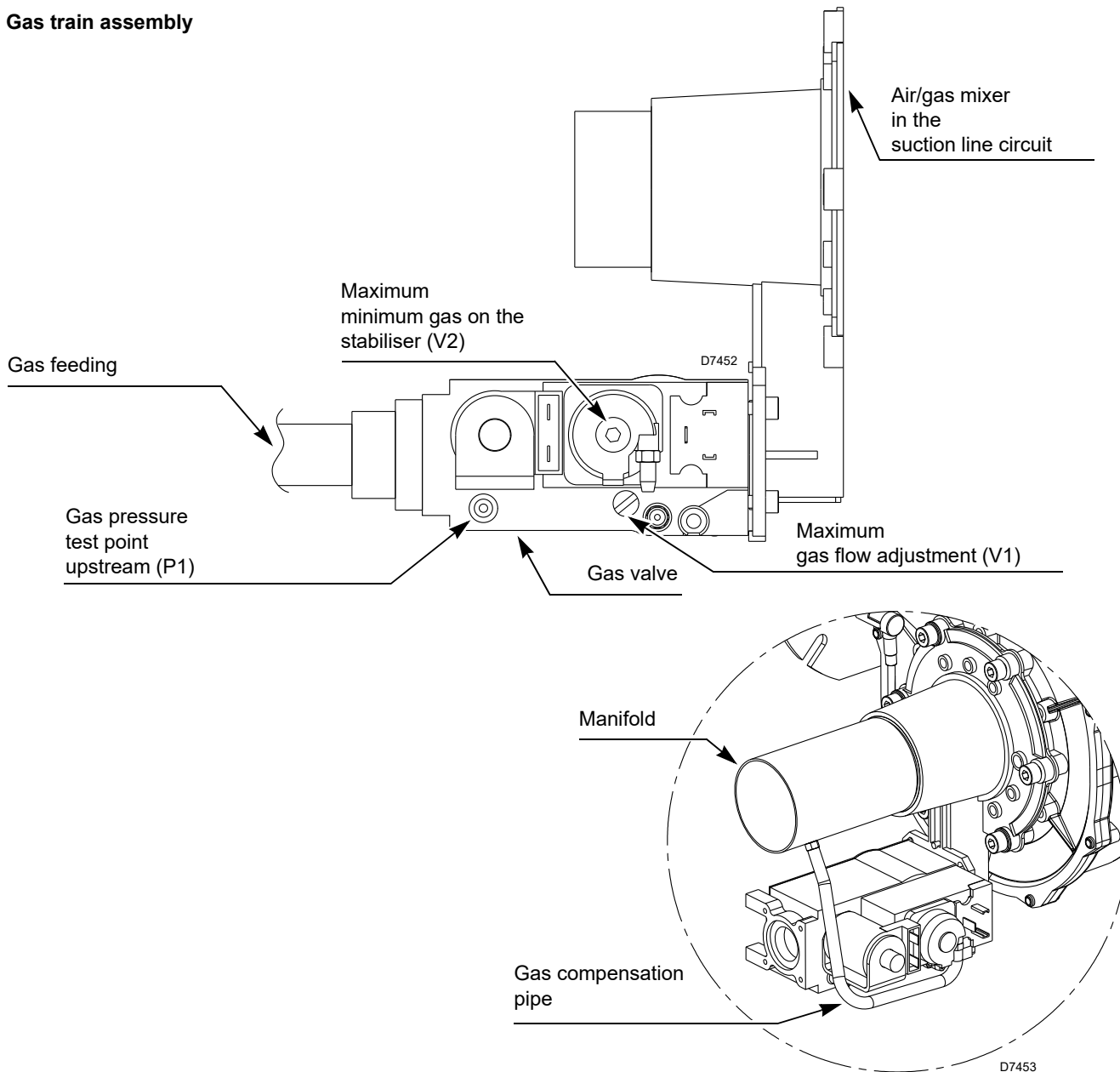

Fig. 13

NOTE:

The connection valve-manifold allows compensating the accidental occlusion of the suction line through the distributed gas reduction.

5.10 Electrical wiring

Notes on safety for the electrical wiring



- The electrical wiring must be carried out with the electrical supply disconnected.
- Electrical wiring must be made in accordance with the regulations currently in force in the country of destination and by qualified personnel. Refer to the wiring diagrams.
- The manufacturer declines all responsibility for modifications or connections different from those shown in the wiring diagrams.
- Check that the electrical supply of the burner corresponds to that shown on the identification label and in this manual.
- The burner has been type-approved for intermittent use. This means they should compulsorily be stopped at least once every 24 hours to enable the control box to perform checks of its own start-up efficiency. Normally, burner stopping is guaranteed by the boiler's thermostat/pressure switch.
- If this is not the case, a time switch should be fitted in series to TL to stop the burner at least once every 24 hours. Refer to the wiring diagrams.
- The electrical safety of the device is obtained only when it is correctly connected to an efficient earthing system, made according to current standards. It is necessary to check this fundamental safety requirement. In the event of doubt, have the electrical system checked by qualified personnel. Do not use the gas tubes as an earthing system for electrical devices.
- The electrical system must be suitable for the maximum power absorption of the device, as indicated on the label and in the manual, checking in particular that the section of the cables is suitable for that level of power absorption.
- For the main power supply of the device from the electricity mains:
 - do not use adapters, multiple sockets or extensions;
 - make provisions for an omnipolar switch with a gap between the contacts of at least 3 mm (over-voltage category III), as required by current safety regulations.
- Do not touch the device with wet or damp body parts and/or in bare feet.
- Do not pull the electric cables.

Before carrying out any maintenance, cleaning or checking operations:

If the cover is still present, remove it and proceed with the electrical wiring according to the wiring diagrams.

Use flexible cables in compliance with the EN 60 335-1 standard.



Disconnect the electrical supply from the burner by means of the main system switch.



After carrying out maintenance, cleaning or checking operations, reassemble the cover and all the safety and protection devices of the burner.



Close the fuel interception tap.



Avoid condensate, ice and water leaks from forming.

6 Start-up, calibration and operation of the burner

6.1 Notes on safety for the first start-up



WARNING

The first start-up of the burner must be carried out by qualified personnel, as indicated in this manual and in compliance with the standards and regulations of the laws in force.



WARNING

Check the correct working of the adjustment, command and safety devices.



WARNING

Before igniting the burner, see the paragraph “Safety test - with gas feeding closed” on page 31.

6.2 Adjustments prior to ignition

The following adjustments must be carried out:

- open the manual valves upline of the gas train;
- release the air from the gas piping using the screw on the gas pressure test point (P1) (Fig. 13 on page 21).
- Adjust the minimum gas pressure switch to the start of the scale.

6.3 Fan adjustment

Modulation is based on variable-speed technology.

The combustion air flow rate can be regulated by varying the motor speed (rpm).

The proportioning gas train delivers the right amount of fuel, depending on the pressure detected in the purging circuit.

So the flow rate supplied is regulated by changing the rotation speed of the motor.

The motor speed can be regulated through an adjustment of the control box.

The adjustments take place via the keys and display on the control box and are carried out using the following parameters:

START	ignition point (P0)
MIN	minimum point (P1)
MAX	maximum point (P2)

NOTE:

The adjustment of the fan (to establish the maximum, minimum and ignition outputs) can occur independently both of the AZL display (see accessories) and the keys and display on board the machine. Below is a description of the procedure to carry out using keys and display on the control box.

6.4 Burner start-up

The burner can operate in two different modes:

- 1 Manual operation (to be used for the initial start-up): in this mode the indicators of the display are blinking;
- 2 Automatic operation (for normal work operation): in this mode the indicators of the display are fixed;.

6.4.1 First burner start-up (manual operation)

To carry out the first start-up of the burner, make sure that:

- The electrical voltage is available (the display of the control box must be lit);
- Open the thermostatic chain (T1-T2 of the 7 pole socket) or, if provided for on the burner, set the "ON-OFF" switch to "OFF";
- Disconnect the external modulation control (control with 3 points or analogue signal);
- Keep the button "A" pressed together with the button "+" or "-" > 5 seconds. The display shows OFF blinking.

NOTE:

if no operation is carried out for a time of >30 seconds, LME7 passes automatically to the normal operation mode. Repeat the above operation.

- Set the "ON/OFF" switch (where provided) to the "ON" position and make sure that there is heat request (thermostat chain closed).
- LME7 starts and carries out a start-up. The device works up to the end of the P30 pre-purging phase, it is brought to the starting load and passes to the display of **P0** (number of rpm ignition load). The display passes from **P0** to a three-digit number.

NOTE:

the three-digit number indicates the setting value for the parameters P0, P1 and P2 as number of revs, and should be multiplied by 10.

- Pressing the button "A" and the button "+" or "-", it is possible to change the number of 10 rpm within pre-set limits (**P0max**, **P0min** factory set values).

NOTE:

the setting for the parameter P0 should be greater than the setting for the parameter P1. The values are checked by the LME7. If the setting rules are violated, the appliance goes into lockout mode, signalling a Loc error:225

- Press the "info" button to confirm the value.
- The burner proceeds with the ignition phase (P36-P38-P40).

NOTE:

If at the end of the safety time the flame does not appear, the burner restarts in automatic mode (it carries out a maximum of 3 attempts). The indications of the sequence of the phases on the display continue to blink to signal that we are still in the start-up procedure (manual operation). If ignition is still not achieved, it may be that gas is not reaching the combustion head within the safety time period. Slowly turn the minimum gas valve screw clockwise to increase the gas flow.

In case of ignition failure after the set attempts, the burner goes into lockout Loc: 07. Press the "info" button for 1..3 seconds unlock the control box.

If the switch remains in the "ON" position (and/or the thermostatic chain is closed) the burner starts again in the standard operating mode (performs all the Ignition phases normally without stopping, at the end of the pre-purge time, at the point **P0**).

To return to manual mode, press button "A" together with the "+" or "-" button > 5 seconds during the pre-purging phase (the value on the display starts to flash).





- The burner is switched on, the program continues to the minimum load position **P1**. The display passes from **P1** to the number of revolutions expressed with three digits.
- Pressing button "A" and the button "+" or "-", it is possible to change the number of 10 rpm within pre-set limits (**P1max**, **P1min** factory set values).
- Check the appearance of the flame, if possible, and the value of the CO and CO2 to understand whether the burner has been sufficiently calibrated (first maximum calibration). If needed, turn the **minimum screw of the gas valve** to increase the gas flow: turn the screw V2 clockwise (tighten); to reduce the gas flow rate: turn the screw V2 anticlockwise (unscrew).
- Press the "info" button to confirm the value.
- The burner then goes to the nominal load position **P2**. The display passes from **P2** to the number of revolutions expressed with three digits.
- Pressing button "A" and the "+" or "-" button, it is possible to change the number of 10 rpm within pre-set limits (**P2max**, **P2min** factory set values).
- Check the appearance of the flame, if possible, and the value of the CO and CO2 to understand whether the burner has been sufficiently calibrated (first maximum calibration). If needed, turn the **maximum screw of the gas valve** to increase the gas flow: turn the screw V1 anticlockwise (unscrew); to reduce the gas flow rate: turn the screw V1 clockwise (tighten).
- Press the "info" button to confirm the value.





NOTE:





If the burner switches off before reaching point P2 (e.g. gas valve too tight, etc.), the burner goes into lockout Loc:07. Press the "info" button for 1..3 seconds unlock the control box and proceed as follows:





- Start the burner with automatic operation (displays fixed).
- LME7 starts and carries out a start-up. The appliance performs the pre-purging phase (P30) and the Ignition phases (P36-P38-P40). Once on, it remains at the Ignition output because the external modulation command is disconnected (operation performed in the preliminary phase).
- Perform the manual modulation procedure as shown below.

MANUAL MODULATION PROCEDURE











 Press  for the current position relative to the actuator or the current speed relative to the PWM fan.
 The indicator light blinks green.
 The display shows **.oP**.





 Press  (1...3 seconds) to display the current position or current speed.
 The indicator light blinks green.
 The relative value **.57** of the current position is displayed.
 Current speed
 0 rpm = 0% display
 The current speed corresponds to the nominal load speed = 100% display
 Example: value **.57**





 Pressing  for > 3 seconds, the point after the number starts to flash. The value is displayed for 2 minutes after the button is released.
 The indicator light blinks green.
 Then the normal screen is displayed.
 Display: value **57**, point. flashes









 Press  for > 3 seconds to alternatively display LoA and 41.
 The relative value **41** of the current position or current speed is displayed.
 Current speed 0 rpm = 0% display
 The current speed corresponds to the nominal load speed = 100% display
 The actual value is displayed (example 41%) and the indicator lamp flashes green.
 Example:
 Position of the actuator or current speed **41%** (based on the interval between high output and 0° or 0 rpm).

Alternatively



 and

 or



 Press  together with  or  to adjust the speed or the position of the actuator or the fan between the low output (x%) and high output (100%).
 Release the buttons when the required position or speed is reached. The indicator light blinks green.
 Example: Value **43**



 Display alternately indicates **LoA** and **43**.
 The indicator light blinks green.
 Example: Required position from the actuator or current speed **43%**

Alternatively



 and



 Press  and  together (Exit) to return to the normal operation.
 Display: **oP**
 At the end of the manual adjustment, the actuator or PWM fan returns to the pre-set analogue output!

- Pressing button **"A"** and button **"+"** increases the fan speed and therefore the burnt output. Slowly increase the speed of the fan checking the appearance of the flame, if possible, and the value of the CO and CO₂ to understand whether the burner has been sufficiently calibrated. If necessary stop increasing the speed and use the **maximum screw of the gas valve** to increase the gas flow rate: turn the screw V1 anticlockwise (unscrew); to reduce the gas flow: turn the screw V1 clockwise (tighten).
- Proceed in steps until the maximum speed is reached (**oP: 100**).
- Press the **"+"** or **"-"** together (ESC function) to return to the normal operation.
- Press button **"A"** together with button **"+"** or **"-"** > **5 seconds** (value flashing on the display) to access the manual operation.
- Pressing the **"info"** button passes from the minimum modulation (P1) to the maximum modulation (P2). Perform these steps to perform the calibration of the minimum and maximum output points.
- Act on the valve settings, using the minimum screw for the minimum output (P1) and the maximum screw for the maximum output (P2), to calibrate the combustion (CO and CO₂).
- Act on the speed values for minimum output (P1) and maximum output (P2) pressing button **"A"** and button **"+"** or **"-"** to modify the 10 rpm.

NOTE:

The value of P2 can be increased up to the predefined maximum value (P2max factory set value). If this value can not be reached (depends on the output and the back pressure of the combustion chamber), the value oP: will be lower than 100 and cannot be confirmed. The P2 value must therefore be decreased until oP can be seen: 100. In this case the value can be confirmed by pressing the "info" key. If no operation is carried out for a time of >30 seconds, LME7 passes automatically to the normal operation mode. Keep the button **"A"** pressed together with the button **"+"** or **"-"** > **5 seconds** to return to the manual operation.

- Press buttons **"+"** or **"-"** together (ESC function) to exit the manual operation and activate the automatic operation.
- Reset the external modulation control (control with 3 points or analogue signal). In the automatic operating position the output requisites of the external load regulator are valid.

NOTE:

When the burner is operating, the control box display shows **"oP:"** meaning modulating operation. The display after **"oP:"** indicates the value in percentage of the speed. The speed corresponding to 100% is that of point P2 (maximum speed).

- To calculate the approximate number of fan revolutions from the percentage **"oP"** it is necessary to multiply the speed set at point P2 by the percentage read (for example, with P2=6000rpm and oP=20% the speed of the fan is about 1200rpm).
- If the speed set at point **P2** is changed (to lower the burnt output, for example) also the current value, equal to **"oP"**, is changed (e.g. P2 = 5000 rpm and oP = 20% the fan speed is about 1000 rpm).

NOTE:

To safeguard the settings on the PME7 program module, a manual backup must be carried out. Also see chapter "Manual Backup".



WARNING

Eventual modifications to the parameters and the settings should be set and saved in the memory on-board the unit.

To save the modified settings of the PME7... program module, the backup should be activated manually. If this is not respected, the safety functions and the set settings could be lost (P0, P1 and P2 values).



WARNING





At the first start-up, or else after replacing the program module, it is necessary to check, immediately after the reset process, the sequence of the functions and the settings of the parameters. If this is not respected you risk losing the safety functions.







WARNING

If the parameters have been changed, you need to make a backup! If this is not respected, the safety functions and the set settings could be lost (P0, P1 and P2 values).



6.5 Manual Backup



 and 
 Press  and  together for >1 second (Esc) to start the manual backup procedure. Parameter **PrC** is displayed.
 Display: **PrC**
 > 1s



 or 
 Press  and  to display parameter **bAC**.
 Display: **bAC**

 1...3 s

 **Run** appears during the download (backup procedure) in the program sequence.

 **End**
 Alternatively  **bAC**
 The display shows **End** and **bAC** alternately.
 The display shows the end of the data exchange.

Appears on the display for 2 minutes or can be terminated by pressing 



When the backup procedure is complete the display shows **OFF**.
 
 Press  for >1 second to reset the unit.
 Display: **OFF**
 > 1s

Tab. N



A backup must be performed if parameters are changed! If the backup is not performed, the safety functions and the set settings could be compromised (P0, P1 and P2 values)!

6.5.1 Error during the backup procedure

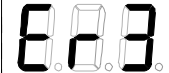
 **bAC**
 Alternatively  **Er3**
 The display shows **bAC** and **Er3** alternately.
 For the meaning of the possible cause, see chapter List of error codes with operation via internal LED.

Tab. O

NOTE:
 During the backup, all the parameters and settings are transferred from the unit's memory to the memory of the program module. Only in this way, in case of replacement of the control box due to a fault, by recovering the program module

from the control box to be replaced and inserting it in the new one, is it possible to recover all the previous settings.

6.6 Fan adjustment

Modulation is based on variable-speed technology.
 Modulation is based on variable-speed technology.
 The combustion air flow rate can be regulated by varying the motor speed (rpm).
 The proportioning gas train delivers the right amount of fuel, depending on the pressure detected in the purging circuit. So the flow rate supplied is regulated by changing the rotation speed of the motor.
 The motor speed can be regulated through an adjustment of the control box.

The adjustments take place on the AZL display on the burner and are carried out using the following parameters:

- START** ignition point (P0) Parameter P 403.00
- MIN** minimum point (P1) Parameter P 403.01
- MAX** maximum point (P2) Parameter P 403.02

NOTE:

The adjustment of the fan (to establish the maximum, minimum and ignition outputs) can occur independently both of the AZL display and the keys and display on board the machine. Below is a description of the procedure to carry out using keys and display on the control box.

6.7 Burner adjustment

The optimum adjustment of the burner requires an analysis of flue gases at the generator outlet.

The burner application at the generator, the adjustment and the testing must be carried out in compliance with the instruction manual of the generator itself, including the control of the concentration of CO and CO₂ in the flue gases and of their temperature.

Check in sequence:

- max output
- min output
- output upon ignition

The **MAX output** should be equal to the value requested by the boiler used. To increase or decrease its value use the external modulation control.

Measure the gas delivery on the counter to precisely establish the burnt output.

Using a smoke analyser, measure the value of the CO₂ or the O₂ in order to optimise the burner calibration.

The correct values are shown in "Combustion head" on page 29.

To correct these values act on the gas valve in the following way:

- to increase the gas delivery and the CO₂: turn the screw V1 anticlockwise (unscrew)(Fig. 13 on page 21);
- to reduce the gas delivery and the CO₂: turn the screw V1 clockwise (tighten) (Fig. 13 on page 21).

The **MIN output** should be equal to the value requested by the boiler used. To increase or decrease its value use the external modulation control.

Measure the gas delivery on the counter to precisely establish the burnt output (to be corrected in relation to the pressure of the gas).

Using a smoke analyser, measure the value of the CO₂ or the O₂ in order to optimise the burner calibration.

The correct values are shown in 6.8.

To correct these values act on the gas valve in the following way:

- to increase the gas delivery and the CO₂: turn the screw V2 clockwise (tighten)(Fig. 13 on page 21);
- to reduce the gas delivery and the CO₂: turn the screw V2 anticlockwise (unscrew) (Fig. 13 on page 21).

The **IGNITION output** should be between the minimum output and the maximum output. To raise or lower its value, adjust the parameter P0) using the control panel of the control box (Fig. 6 on page 12).



Do not modify the adjustments of the gas valve for the ignition output!

6.7.1 Optimum calibration values

	MIN output		MAX output	
	CO ₂ (%)	O ₂ (%)	CO ₂ (%)	O ₂ (%)
Methane	8	6.6	8.5	5.7
LPG	9.5	6.4	10	5.6
G25	7.8	6.8	8.3	5.8

Tab. P



Импортер
 в Республику Беларусь
8 (029) 11 915 11 INFO@SMARTFLAM.BY

6.8 Combustion head

The combustion head comprises a highly heat resistant cylinder whose surface features numerous holes, encased in a metal "mesh". The air-gas mixture is pushed inside the cylinder and out of the head through the holes in the perimeter.

Combustion starts when the air-gas mixture is ignited by a spark generated by the electrode.

The metal "mesh" is the combustion head's most essential element since it improves burner performance considerably.

The flame developed on the surface of the head is perfectly retained and adheres to the mesh when operating at the maximum setting. This allows modulating ratios as high as 6:1, avoiding the danger of flashback when modulating is at its minimum.

The flame features an extremely compact geometry, meaning that there is no risk of contact between the flame and parts of the boiler, consequently eliminating the possible problem of poor combustion.

The flame's structure means that smaller combustion chambers can be developed, designed to exploit this particular feature.

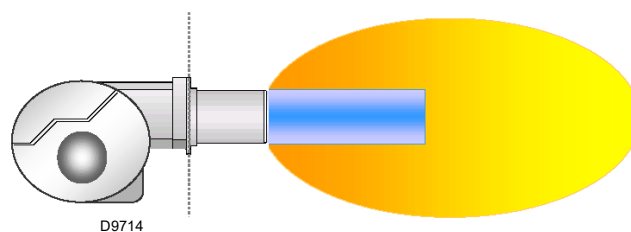

Fig. 14







Before starting up the burner, it is good practice to adjust the gas train so that ignition takes place in conditions of maximum safety, i.e. with gas delivery at the minimum.

6.9 Setting and safety parameters (programmed control box)

No.	Parameter	OEM-preset	Value
1	pre-purging time	30	Seconds
2	Safety time	3	Seconds
3	Flame stabilisation time	10	Seconds
4	Ignition attempts	3	Number
5	Post-purging time	0	Seconds
6	Pre-ignition time	3	Seconds
7	Attempts in the event of flame loss during operation	1	Number
8	Pre-post purging speed	5300	Rotations/min
9	Number of fan rotations: number of ignition load rotations (P0)	2100	Rotations/min
10	Number of fan rotations: number of minimum load rotations (P1)	1320	Rotations/min
11	Number of fan rotations: number of nominal load rotations (P2)	5800	Rotations/min
12	Limit number of ignition load rotations (P0) Minimum limit	2100	Rotations/min
13	Limit number of ignition load rotations (P0) Maximum limit	4020	Rotations/min
14	Limit number of minimum load rotations (P1) Minimum limit	1320	Rotations/min
15	Limit number of minimum load rotations (P1) Maximum limit	2280	Rotations/min
16	Limit number of nominal load rotations (P2) Minimum limit	4020	Rotations/min
17	Limit number of nominal load rotations (P2) Maximum limit	6000	Rotations/min
18	Maximum number of fan rotations	8400	Rotations/min
19	Minimum load → nominal load ascending ramp	20	Seconds
20	Nominal load → minimum load descending ramp	20	Seconds
21	Pulses for rotation	2	Pulses/rotation
22	Analogue input (Return signal potentiometer ASZxx.3x)	0	-
	0: 3-point input 1: 0-10 V 2: 0-135 Ω 3: 0-20 mA 4: 4-20 mA with lockout at I < 4 mA 5: 4-20 m		

Tab. Q

6.10 Final checks (with burner operating)

<ul style="list-style-type: none">➤ Open the thermostat/pressure switch TL➤ Open the thermostat/pressure switch TS		The burner must stop
<ul style="list-style-type: none">➤ Turn the gas maximum pressure switch knob to the minimum end of scale position (where present)		The burner must stop in lockout
<ul style="list-style-type: none">➤ Turn off the burner and cut off the power➤ Disconnect the minimum gas pressure switch connector		The burner must not start
<ul style="list-style-type: none">➤ Disconnect the wire of the ionisation probe		The burner performs the ignition cycle again

Tab. R**WARNING**

Make sure that the mechanical locking systems on the various adjustment devices are fully tightened.

7.1 Notes on safety for the maintenance

The periodic maintenance is essential for the good operation, safety, yield and duration of the burner.

It allows you to reduce consumption and polluting emissions and to keep the product in a reliable state over time.



DANGER

The maintenance interventions and the calibration of the burner must only be carried out by qualified, authorised personnel, in accordance with the contents of this manual and in compliance with the standards and regulations of current laws.

Before carrying out any maintenance, cleaning or checking operations:



DANGER

Disconnect the electrical supply from the burner by means of the main system switch.



DANGER

Close the fuel interception tap.



Wait for the components in contact with heat sources to cool down completely.

7.2 Maintenance programme

7.2.1 Maintenance frequency



The gas combustion system should be checked at least once a year by a representative of the manufacturer or another specialised technician.

7.2.2 Safety test - with gas feeding closed

For its safe commissioning it is very important to make sure that the electrical wiring has been carried out correctly between the gas valves and the burner.

To this end, after checking that the connections have been made in conformity with the burner's wiring diagrams, a starting cycle should be carried out with the gas tap closed (dry test).

- 1 The manual gas valve should be closed with the locking/releasing device ("lock-out / tag out" procedure).
- 2 Make sure the limit electric contacts of the burner close.
- 3 Make sure the contact of the minimum gas pressure switch closes (where foreseen).
- 4 Proceed with a tentative start up of the burner.

The starting cycle should occur with the following phases:

- Starting the fan motor for pre-purging
- Carrying out the gas valve leak detection control, if applicable.
- Completing the pre-purging
- Reaching the ignition point
- Power supply of the ignition transformer
- Power supply the gas valves.

Since the gas is closed, the burner will not be able to start and its control box will stop or go into a safety lockout after the ignition attempts set in the control box programming (usually 3 attempts).

The effective supplying of the gas valves can be checked with the insertion of a tester; some valves are fitted with light signals (or closure/opening position indicators) that are activated when the electrical supply arrives.



WARNING

IF THE ELECTRICAL SUPPLY OF THE GAS VALVES OCCURS AT AN UNEXPECTED MOMENT, DO NOT OPEN THE MANUAL VALVE, DISCONNECT THE ELECTRICAL SUPPLY, CHECK THE WIRING; CORRECT THE ERRORS AND CARRY OUT THE ENTIRE TEST AGAIN.

7.2.3 Checking and cleaning



The operator must use the required equipment during maintenance.

Combustion head

Open the burner and make sure that all components of the combustion head are in good condition, not deformed by the high temperatures, free of impurities from the surroundings and correctly positioned.

Electrodes assembly

Make sure neither the electrodes nor probe show marked warping or oxidation on surfaces. Make sure distances indicated (Fig. 11 and Fig. 12) are still being complied with, otherwise readjust to the right values where necessary. Where necessary, remove oxide from the surface of the probe with abrasive paper.

Burner

Check that there are not excess wear or loosen screws.
Clean the outside of the burner.
Clean and grease the adjustable profile of the cams.

Fan

Check the fan for dirt. A build-up of dust: a reduction in the air flow rate and provoke polluting combustion.

Boiler

Clean the boiler as indicated in its accompanying instructions in order to maintain all the original combustion characteristics intact, especially: the flue gas temperature and combustion chamber pressure.

Gas leaks

Check that there are no gas leaks on the meter-burner pipe. Check that there are no gas leaks in the following areas:

- on the meter-burner pipework
- on the mixer/valve connection
- on the burner fastening flange where the seal is fitted.

Gas filter

Change the gas filter when it is dirty.

Measuring circuit for measuring the current detector

The minimum current necessary for the control box operation is 1 µA. The burner normally supplies a higher current value, so that no check is needed.

Anyway, if you want to measure the ionisation current, you need to open the connector (CN1) fitted on the red wire and insert a microammeter.

Flame control

Displayed value:

MIN 1 µA = 20%

MAX 40 µA = 100%

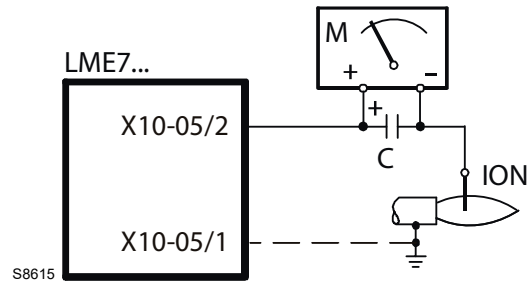

Fig. 15

Key to layout (Fig. 15)

C Electrolytic capacitor 100...470 µF; DC 10...25 V

ION Ionisation probe

M Microammeter Ri max. 5,000 Ω



Alternatively, it is possible to check the quality of the ionisation current measured by the control box using the control box itself as described below.

Display of the ION or QRA flame... current

Press to display the signal of the flame amplifier.
The indicator light blinks green.
Display shows **FL.1**

Press (1...3 seconds), to display the current flame signal.
The indicator light blinks green.
Example: **11**

Pressing (> 3 seconds), the point after the number starts to flash.
The value is displayed for 2 minutes after the button is released.
The indicator light blinks green.
Then the normal screen is displayed.
Display: point **.** blinks, the value **11** does not blink.



This display is possible only in operating mode or in stand-by!

Tab. S

Combustion

The optimum calibration of the burner requires an analysis of the flue gases.

Significant differences with respect to the previous measurements indicate the points where more care should be exercised during maintenance.

In case the combustion values found at the beginning of the intervention do not respect the standards in force or, in any case, do not correspond to a proper combustion, contact the Technical Assistance Centre in order to carry out the necessary adjustments.

	MIN output		MAX output	
	CO ₂ (%)	O ₂ (%)	CO ₂ (%)	O ₂ (%)
Methane	8	6.6	8.5	5.7
LPG	9.5	6.4	10	5.6
G25	7.8	6.8	8.3	5.8

Tab. T

7.2.4 Safety components

The safety components should be replaced at the end of their life cycle indicated in Tab. U. The specified life cycles do not refer to the warranty terms indicated in the delivery or payment conditions.

Safety component	Life cycle
Flame control	10 years or 250,000 operation cycles
Flame sensor	10 years or 250,000 operation cycles
Gas valves (solenoid)	10 years or 250,000 operation cycles
Pressure switches	10 years or 250,000 operation cycles
Pressure adjuster	15 years
Servomotor (electronic cam) (if present)	10 years or 250,000 operation cycles
Oil valve (solenoid) (if present)	10 years or 250,000 operation cycles
Oil regulator (if present)	10 years or 250,000 operation cycles
Oil pipes/ couplings (metallic) (if present)	10 years
hoses (if present)	5 years or 30,000 pressurised cycles
Fan impeller	10 years or 500,000 start-ups

Tab. U

7.3 Opening and closing the burner



DANGER

Disconnect the electrical supply from the burner by means of the main system switch.



Wait for the components in contact with heat sources to cool down completely.



DANGER

Close the fuel interception tap.



After carrying out maintenance, cleaning or checking operations, reassemble the cover and all the safety and protection devices of the burner.

WWW.SMARTFLAM.BY 
SmartFlam

Импортер
 в Республику Беларусь
 8 (029) 11 915 11 INFO@SMARTFLAM.BY

7.4 Recommended preventive maintenance programme

The use and maintenance instructions are meant for general applications. For specific use and maintenance instructions, contact the manufacturer of the control box.

Test/Inspection	Frequency
	DAILY
Checking adjustments of instruments and control boxes	DAILY
Checking burner flame	DAILY
Checking ignition device	WEEKLY
Checking flame signal strength	WEEKLY
Checking flame fault control system	WEEKLY
Checking firing rate command	WEEKLY
Visual and acoustic control of the pilot and fuel valves	WEEKLY
Checking fuel, venting, flue or inlet gates	MONTHLY
Test for low updraught, fan air pressure and damper position lockout	MONTHLY
Check low flame start lockout	MONTHLY
High and low gas pressure lockout test	MONTHLY
Recalibration of all the adjustment components	SIX-MONTHLY
Check of system components for detecting flame fault	SIX-MONTHLY
Check of firing rate command	SIX-MONTHLY
Check of piping and cabling of all the lockouts and shut-off valves	SIX-MONTHLY
Inspection of burner components	SIX-MONTHLY
Flame fault detection system, test for hot refractory content	YEARLY
Replacing flame rod according to the manufacturer's instruction	YEARLY
Carrying out a combustion test	YEARLY
Check of coils and diaphragms; testing other operating parts of the control valves and safety shut-off valves	YEARLY
test of the interlocking switch of the fuel valve according to the manufacturer's instructions	YEARLY
Tests for leaks on pilot valves and gas valves	YEARLY
Testing air discharge switch according to the manufacturer's instructions	YEARLY
Testing low flame starting lockout according to the manufacturer's instructions	YEARLY
For gas burners, check the sediment well and the gas filters	AS REQUIRED
Flame fault detection system, test for hot refractory content	AS REQUIRED

Tab. V

8

Operation, indications, diagnostic

8.1 Control sequence in the event of a fault

In the event of a lockout, the outlets for fuel valves, burner motor and ignition devices should be immediately deactivated (<1 second).

Causes	Answer
Mains voltage interruption	Restart
Voltage below the undervoltage threshold	Safety switch off
Voltage above the undervoltage threshold	Restart
Extraneous light before the safety time	Lockout
Extraneous light during the standby time	Starting pre-purging, lockout after about 30 seconds maximum
No flame at the end of the safety time	Lockout at the end of the safety time
Flame loss during the operation	Factory settings: lockout Can be configured: (depending on the program module 1 x repetition)
Min. pressure switch fault during operation (where foreseen)	Switching of and on the pre-purging

Tab. W

In the event of a lockout, the LME71... remains in lockout and the red fault indicator lamp comes on. The burner control can be immediately released. This state is maintained also when the mains supply is interrupted.

8.2 Error code list with operation via the control box control panel

Error code	Clear text	Possible cause
bAC Er3	Programme module compatibility fault with the base unit during the back-up process	The program sequence of the program module is not compatible with the base unit
Err PrC	Fault with the program module	<ul style="list-style-type: none"> – Error in the data contained in the program module – No program module
Loc 2	No flame at the end of the safety time	<ul style="list-style-type: none"> – Fuel valves dirty or defective – Flame detector dirty or defective – Burner not adjusted correctly, no fuel – Ignition device defective
Loc 3	Error with air pressure switch (air pressure switch soldered in position with no load), reduction to specified time (air pressure switch) response time)	Air pressure switch faulty <ul style="list-style-type: none"> – Loss of air pressure signal after the specified time – The air pressure switch is soldered in a position without load
Loc 4	Extraneous light	Burner start-up extraneous light
Loc 5	Air pressure error, air pressure switch soldered in an operating position	Air pressure switch time out <ul style="list-style-type: none"> – The air pressure switch is soldered in an operating position
Loc 6	Fault with the actuator	<ul style="list-style-type: none"> – Actuator defective or blocked – Faulty connection – Incorrect adjustment
Loc 7	Flame loss	<ul style="list-style-type: none"> – Too many flame losses during operation (limitation of repetitions) – Fuel valves dirty or defective – Flame detector dirty or defective – Burner adjustment incorrect
Loc 8	---	Free
Loc 9	---	Free
Loc 10	Non attributable error (application), internal error	Wiring error or internal error, outlet contacts, other faults
Loc 12	Valve test	Fuel valve 1, leak
Loc 13	Valve test	Fuel valve 2, leak
Loc 14	POC error	POC error valve closure control
Loc 20	Min gas pressure switch open	No gas
Loc 22	Safety loop open	<ul style="list-style-type: none"> – Max gas pressure switch open – Limit thermostat safety lockout
Loc 60	Analogue power supply source 4...20 mA, I < 4 mA	Wire broken
Loc: 83	PWM fan faulty	<ul style="list-style-type: none"> – The PWM fan does not reach the expected speed within the pre-set period of time, or – After reaching the expected speed, the PWM fan once again falls outside the tolerance range (P650) for a period of time greater than the time admissible for speed deviation (P660)
Loc 138	Reset process successful	Reset process successful
Loc 139	No program module detected	No program module identified
Loc 167	Manual lockout	Manual lockout
Loc: 206	AZL2... incompatible	Use the latest version
Loc: 225	PWM fan faulty	<ul style="list-style-type: none"> – The fan speed dropped below the PWM pre-purging maximum (P675.00) after reaching the pre-purging speed, or – After reaching the ignition load speed, the PWM maximum ignition load (P675.01) was exceeded
Loc: 226	PWM fan faulty	Configuration error: <ul style="list-style-type: none"> – Low flame speed > high flame speed, or – Low flame = 0 rpm, or – Maximum speed = 0 rpm
Loc: 227	PWM fan faulty	One or more parameters violate the minimum/maximum limit
rSt Er1	Programme module compatibility fault with the base unit during the reset process	The sequence of the program module is not compatible with the base unit
rSt Er2	Programme module compatibility fault with the base unit during the reset process	The hardware of the base unit is not compatible with the program module
rSt Er3	Error during the reset process	<ul style="list-style-type: none"> – Fault with the program module – Program module removed during the reset process

Tab. X

8.3 Resetting of burner control

When a lockout occurs, the burner control can be immediately released by pressing the "RESET" button.

NOTE:

For the meaning of the diagnostic codes and errors, see the chapter "Error code list with operation via the control box control panel" on page 36.

8.3.1 Diagnostics of the cause of the fault

After the lockout, the faults indicator lamp stays on fixed. Under these conditions, it is possible to activate the visual diagnostic of the cause of the fault based on the table of colour codes by keeping the reset button pressed for more than 3 seconds (info button).

Press the reset button again (info button) for at least 3 seconds to activate the diagnostics interface.

If the diagnostic interface is started accidentally, a condition signalled by the blinking red indicator light, it can be deactivated by pressing the reset button again (info button) for > 3 seconds.

The switching moment is indicated by a pulse of yellow light.

Error code table

Red blink code fault indicator light	Possible cause
2 blinks	No flame at the end of the safety time – Fuel valves dirty or defective – Flame detector dirty or defective – Burner not adjusted correctly, no fuel – Ignition device defective
4 blinks	– Extraneous light at burner start-up
7 blinks	Too many flame losses during operation (limitation of repetitions) – Fuel valves dirty or defective – Flame detector dirty or defective – Burner adjustment incorrect
8 blinks	Free
9 blinks	Free
10 blinks	Wiring error or internal error, outlet contacts, other faults
12 blinks	Valve test – Fuel valve 1 leak
13 blinks	Valve test – Fuel valve 2 leak
14 blinks	POC error valve closure control
15 blinks	Error code ≥ 15 (e.g. according to the type of program module) error code 20: Min gas pressure switch fault error code 22: Safety loop error

Tab. Y

During the diagnosis of the cause of the fault, the outputs of the controls are disabled

- The burner stays off
- Indication of external fault (alarm) on the clamp X2-03, foot 3 on fixed

At the outlet of the diagnostic of the cause of the fault the burner is switched on again by resetting the burner control.

Press the reset button (info button) for about 1 second (< 3 seconds).

8.3.2 Before starting with a new program module or when the program module is replaced



Alternatively



- The display shows **rSt** and **PrC** alternately.
- The display shows the replacement of the program module.
- The indicator light blinks alternately one red and two yellow.

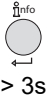

- Press for >3 to start the download of the program module data.
The indicator light blinks yellow.
 - The process that lasts 3 seconds is accompanied by short yellow blinking.
- Note:
- If you press for <3 seconds, the download does not start. To restart the reset process, you need to reset the LME7... switching the mains ON/OFF.

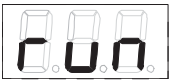

The display shows 'run' during the download (reset process) of the program sequence.



Alternatively



- The display shows **rSt** and **End** alternately.
- The display shows the end of the data exchange.

After 2 minutes, the unit passes to **Loc 138**

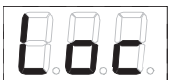

Alternatively



- At the end of the reset process, the unit is automatically in a lockout position (LOC 138) and need to be released in order to work!



- Press for >1 second to release the unit.
- Display: **OFF**

Tab. Z



WARNING

At the first start-up or after replacing the program module, after the completion of the restore process the sequence of the functions and the parameter settings should be checked.





WARNING

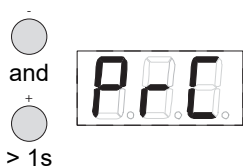

Replacing the program module will result in the loss of any settings made previously on the control box.

8.4 Manual reset



Press contemporaneously  and  for >1 second (Escape) to start the manual reset process. The parameter **PrC** appears.
Display: **PrC**



Press  and  for the parameter **rSt**.
Display: **rSt**

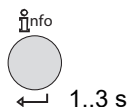

run appears during the download (restore process) of the program sequence.



Alternatively



● **At the end of the reset process, the unit is automatically in a lockout position (LOC 138) and need to be released in order to work!**

After 2 minutes, the unit passes to **Loc 138**



Alternatively



● **At the end of the reset process, the unit is automatically in a lockout position (LOC 138) and need to be released in order to work!**



Press  for >1 second to release the unit.
Display: **OFF**

8.4.1 Error during the reset process



Alternatively
with

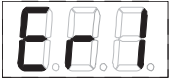

or



or



The display shows **rSt** and **Er1**, **Er2** or **Er3**.

For the meaning of the possible cause, see the chapter "Error code list with operation via the control box control panel" on page 36.

Tab. AB

NOTE:

During the restore process, all the parameters and settings are written from the program module onto the memory integrated into the device. During this process it is possible that the previous program sequences, the parameters and the settings in the internal memory could be overwritten!

8.4.2 Reset

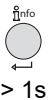

Pressing for 1...3 seconds displays OFF.

When the button is released the unit has been reset.

Tab. AC

NOTE:

For the meaning of the diagnostic and error codes, see the chapter "Error code list with operation via the control box control panel" on page 36.

A List of parameters PME71.901...)

The following pages have the Menus and the list of parameters for setting up the LCD AZL 2 ... Display for the LME 71 ... control box with PME 71.901 ...



To display/change the parameters it is necessary to use the AZL 21 ... display kit (page 44) accessing with the password.

The values shown in the "Factory setting" column in the table below, are indicative (Control box not programmed).

Parameter		Modification	Value range		Resolution	Factory Setting	Password reading level to level	Password writing level to level
No.	Description		Min.	Max.				
000	Internal parameter							
41	Password for heating engineering (4 characters)	Modification	xxxx	xxxx	---	---	---	OEM
42	Password OEM (5 characters)	Modification	xxxxx	xxxxx	---	---	---	OEM
60	Backup/restore	Modification	Restore	Backup	---	---	---	SO
100	General notes							
102	Identification date	Reading only	---	---	---	---	mode	---
103	Identification number	Reading only	0	9999	1	0	mode	---
113	Burner identification	Modification	x	xxxxxxx	1	burnErd	mode	SO
123	Step control min output.	Modification	1%	10%	0.1	2	SO	SO
140	Displaying the unit operation mode and displaying AZL2... 1 = standard (program phase) 2 = flame 1 (QRA.../ION) 3 = flame 2 (QRB.../QRC...) @ not used 4 = output active (output value)	Modification	1	4	1	4	SO	SO
164	Number of resettable start-ups	Resettable	0	999999	1	0	mode	mode
166	Total number of start-ups	Reading only	0	999999	1	0	mode	---
170.00	Switching cycles relay contact K12	Reading only	0	999999	1	0	mode	---
170.01	Switching cycles relay contact K11	Reading only	0	999999	1	0	mode	---
170.02	Switching cycles relay contact K2	Reading only	0	999999	1	0	mode	---
170.03	Switching cycles relay contact K1	Reading only	0	999999	1	0	mode	---
171	Max. relay commutation cycles	Reading only	0	999999	1	0	mode	---
200	Burner Control							
224	Air pressure switch special time	Modification	0s	13.818 s	0.294 s	13.818 s	SO	OEM
225	Pre-purging time - 2.1 seconds	Modification	0s	1237 s	4.851 s	29.106 s	SO	OEM
226	Spark pre-ignition time	Modification	1.029 s	37.485 s	0.147 s	6.174 s	SO	OEM
230	Interval: End of the safety time - resetting of the load regulator	Modification	3.234 s	74.97 s	0.294 s	9.408 s	SO	OEM
234	Post-purging time	Modification	0s	1237 s	4.851 s	19.404 s	SO	OEM
235	Air pressure switch input 0 = inactive 1 = active	Modification	0	1	1	0	SO	OEM
240.00	Repetitions meter Limit value of flame loss during operation	Modification	0	2	1	0	SO	OEM
240.01	Repetitions meter Limit value of No flame at the end of the safety time	Modification	0	1	1	1	SO	OEM
241.00	Valves Seal Control 0 = OFF 1 = ON	Modification	0	1	1	1	SO	OEM
241.01	Valves Seal Control 0 = during pre-purging 1 = during post-purging	Modification	0	1	1	1	SO	OEM
241.02	Valves Seal Control 0 = according to P241.01 1 = during pre-purging and post-purging	Modification	0	1	1	0	SO	OEM
242	Evacuation of valve seal control test area	Modification	0s	2.648 s	0.147 s	2.648 s	SO	OEM
243	Atmospheric pressure valve seal control time test	Modification	1.029 s	37.485 s	0.147 s	10.290 s	SO	OEM
244	Filling the valve seal control test area	Modification	0s	2.648 s	0.147 s	2.648 s	SO	OEM
245	Gas pressure valve seal control time test	Modification	1.029 s	37.485 s	0.147 s	10.290 s	SO	OEM

Parameter		Modification	Value range		Resolution	Factory Setting	Password reading level to level	Password writing level to level
No.	Description		Min.	Max.				
257	Post-ignition time -0.3 seconds	Modification	0s	13.23 s	0.147 s	2.205 s	SO	OEM
400	Ratio control (operation)							
403.00	Fan speed: Ignition load speed (P0)	Modification	800 rpm	900 rpm	10 rpm	3000 rpm	SO	SO
403.01	Fan speed: Low flame speed (P1)	Modification	800 rpm	900 rpm	10 rpm	1200 rpm	SO	SO
403.02	Fan speed: High flame speed (P2)	Modification	800 rpm	900 rpm	10 rpm	5700 rpm	SO	SO
500	Ratio control							
503.00	Speed without PWM fan flame: Standby speed	Modification	0 rpm	9000 rpm	10 rpm	0 rpm	SO	SO
503.01	Speed without PWM fan flame: Speed of impurity purge	Modification	800 rpm	9000 rpm	10 rpm	5700 rpm	SO	SO
516.00	Limit of ignition load speed (P0): Minimum limit	Modification	800 rpm	9000 rpm	10 rpm	800 rpm	SO	OEM
516.01	Limit of ignition load speed (P0): Maximum limit	Modification	800 rpm	9000 rpm	10 rpm	9000 rpm	SO	OEM
517.00	Limit of low flame speed P1: Minimum limit Modification	Modification	800 rpm	9000 rpm	10 rpm	800 rpm	SO	OEM
517.01	Limit of low flame speed P1: Maximum limit	Modification	800 rpm	9000 rpm	10 rpm	9000 rpm	SO	OEM
518.00	Limit of high flame speed P2: Minimum limit	Modification	800 rpm	9000 rpm	10 rpm	800 rpm	SO	OEM
518.01	Limit of high flame speed P2: Maximum limit	Modification	800 rpm	9000 rpm	10 rpm	9000 rpm	SO	OEM
519	Maximum fan speed	Modification	3000 rpm	9000 rpm	10 rpm	5830 rpm	SO	OEM
522	low flame acceleration @ high flame	Modification	2.058 s	74.970 s	0.294 s	14.994 s	SO	OEM
523	High flame acceleration @ low flame	Modification	2.058 s	74.970 s	0.294 s	14.994 s	SO	OEM
558	Mode: Information UDS status 0 = PC tool mode 1 = PWM mode 2 = actuator mode 3 = internally 4 = internally 5 = internally	Reading only	0	5	1	0	SO	---
559	PWM mode 0 = open loop control 1 = PID control 2 = safety mode (PWM limits)	Modification	0	2	1	1	SO	OEM
560	Mode: Control of pneumatic ratio 0 = OFF 1 = PWM fan 2 = air damper actuator	Reading only	0	2	1	1	SO	---
600	Output setting							
644	Number of pulses for rotation	Modification	2	5	1	3	SO	OEM
646	Time of speed control adjustment	Modification	1.029 s	2.058 s	0.147 s	2.058 s	SO	OEM
650.00	Speed tolerance range: Stopping speed	Modification	1%	5%	1%	1%	SO	OEM
650.01	Speed tolerance range: Rapid stopping speed	Modification	1%	10%	1%	3%	SO	OEM
654	Analogue input (feedback potentiometer ASZxx.3x required) 0 = input passage 3 positions 1 = 0...10 V 2 = 0...135 W 3 = 0...20 mA 4 = 4...20 mA with lockout at I <4 mA 5 = 4...20 mA	Modification	0	5	1	1	SO	SO
658.00	PWM fan values: PWM starting	Modification	1%	100%	1%	25%	SO	OEM
658.01	PWM values fan: Min. PWM operating range	Modification	0%	20%	1%	0%	SO	OEM
658.02	PWM values fan: Max. PWM operating range	Modification	80%	100%	1%	100%	SO	OEM
659.00	Ramp time of fan: Min. low-fire to high-fire	Reading only	0s	74.970 s	0.294 s	2.058 s	SO	---
659.01	Ramp time of fan: Max. from high flame to low flame	Reading only	0s	74.970 s	0.294 s	74.970 s	SO	---
659.02	Ramp time of fan: Min. high-fire to low-fire	Reading only	0s	74.970 s	0.294 s	2.058 s	SO	---
659.03	Ramp time of fan: Max. high-fire to low-fire	Reading only	0s	74.970 s	0.294 s	74.970 s	SO	---
660	Tolerance time speed deviation	Reading only	0s	37.85 s	0.147 s	4.998 s	SO	---
674	Neutral interval (control offset permitted)	Modification	0 rpm	255 rpm	1 rpm	40 rpm	SO	OEM

Parameter		Modification	Value range		Resolution	Factory Setting	Password reading level to level	Password writing level to level
No.	Description		Min.	Max.				
675.00	PWM: Min. PWM with pre-purging, SEC	Modification	0%	100%	1%	86%	SO	OEM
675.01	PWM: Max. PWM with ignition load, SEC	Modification	0%	100%	1%	34%	SO	OEM
676	Gain factor speed control	Reading only	0	255	1	112	SO	---
677	Integral action time speed control	Reading only	0s	37.485 s	0.147 s	0.441 s	SO	---
678	Derivative action time speed control	Reading only	0s	37.485 s	0.147 s	0s	SO	---
679.00	Constant time speed control PT1: Min. speed interval from high flame to low flame	Modification	0s	37.485 s	0.147 s	6.027 s	SO	OEM
679.01	Constant time speed control PT1: Average speed interval from high flame to low flame	Modification	0s	37.485 s	0.147 s	6.027 s	SO	OEM
679.02	Constant time speed control PT1: Upper speed interval from high flame to low flame	Modification	0s	37.485 s	0.147 s	6.027 s	SO	OEM
679.03	Constant time speed control PT1: Total speed interval from high flame to low flame	Modification	0s	37.485 s	0.147 s	6.027 s	SO	OEM
680.00	Speed interval for constant time PT1: Upper speed interval threshold	Modification	800 rpm	9000 rpm	10 rpm	4000 rpm	SO	OEM
680.01	Speed interval for constant time PT1: Lower speed interval threshold	Modification	800 rpm	9000 rpm	10 rpm	2000 rpm	SO	OEM
700	Error history							
701.00	Current error: Error code	Reading only	2	255	1	---	mode	---
701.01	Current error: Start-up meter reading	Reading only	0	999999	1	---	mode	---
701.02	Current error: MMI phase	Reading only	---	---	---	---	mode	---
701.03	Current error: Power value	Reading only	0%	100%	1	---	mode	---
702.00	Error history former 1: Error code	Reading only	2	255	1	---	mode	---
702.01	Error history o1: Start-up meter reading	Reading only	0	999999	1	---	mode	---
702.02	Error history o1: MMI phase	Reading only	---	---	---	---	mode	---
702.03	Error history o1: Power value	Reading only	0%	100%	1	---	mode	---
•								
•								
•								
711.00	Error history former 10: Error code	Reading only	2	255	1	---	mode	---
711.01	Error history former 10: Start-up meter reading	Reading only	0	999999	1	---	mode	---
711.02	Error history former 10: MMI phase	Reading only	---	---	---	---	mode	---
711.03	Error history former 10: Power value	Reading only	0%	100%	1	---	mode	---
900	Process data							
920	Current PWM signal fan	Reading only	0%	100%	1%	---	mode	---
936	Normalized speed	Reading only	0%	100%	0.01%	---	mode	---
951	Mains voltage	Reading only	0 V	LME 71.000 A1: 175 V LME 71.000 A2: 350 V	1 V	---	mode	---
954	Flame intensity	Reading only	0%	100%	1%	---	mode	---

Tab. AD

B Appendix - Accessories

7 pole socket with filter kit

The connection kit filtered with a 7 pin/plug socket is necessary to counter the radio disturbances coming from the electrical power supply.

Burner	Code
RX 150 S/PV	on demand

Software diagnostics kit

A special kit is available that, by a link to a PC, shows the burner life together with operating hours, type and number of lockouts, no. of motor rpm and safety parameters.

Burner	Code
RX 150 S/PV	on demand

To display the diagnostics proceed as follows:

- connect the kit (supplied separately) to the appropriate socket on the control box. Reading of the information begins when the software programme included in the kit starts.

Kit display LCD AZL 2... for control box LME 71... with PME 71.901

Burner	Code
RX 150 S/PV	20109292



WARNING

The installer is responsible for the addition of any safety device not foreseen in this manual.

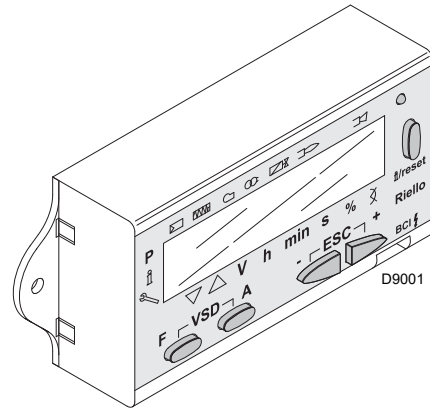

Fig. 16

Gas trains in compliance with EN 676

Please refer to manual.

C Appendix - Electrical panel layout

1	Index of layouts
2	Indication of references
3	Functional diagram
4	Functional diagram
5	Functional diagram
6	Functional diagram
7	Electrical wiring that the installer is responsible for

2 Indication of references

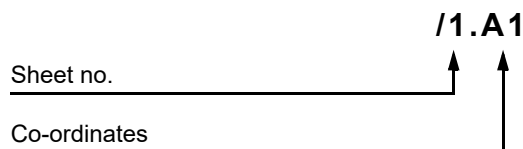

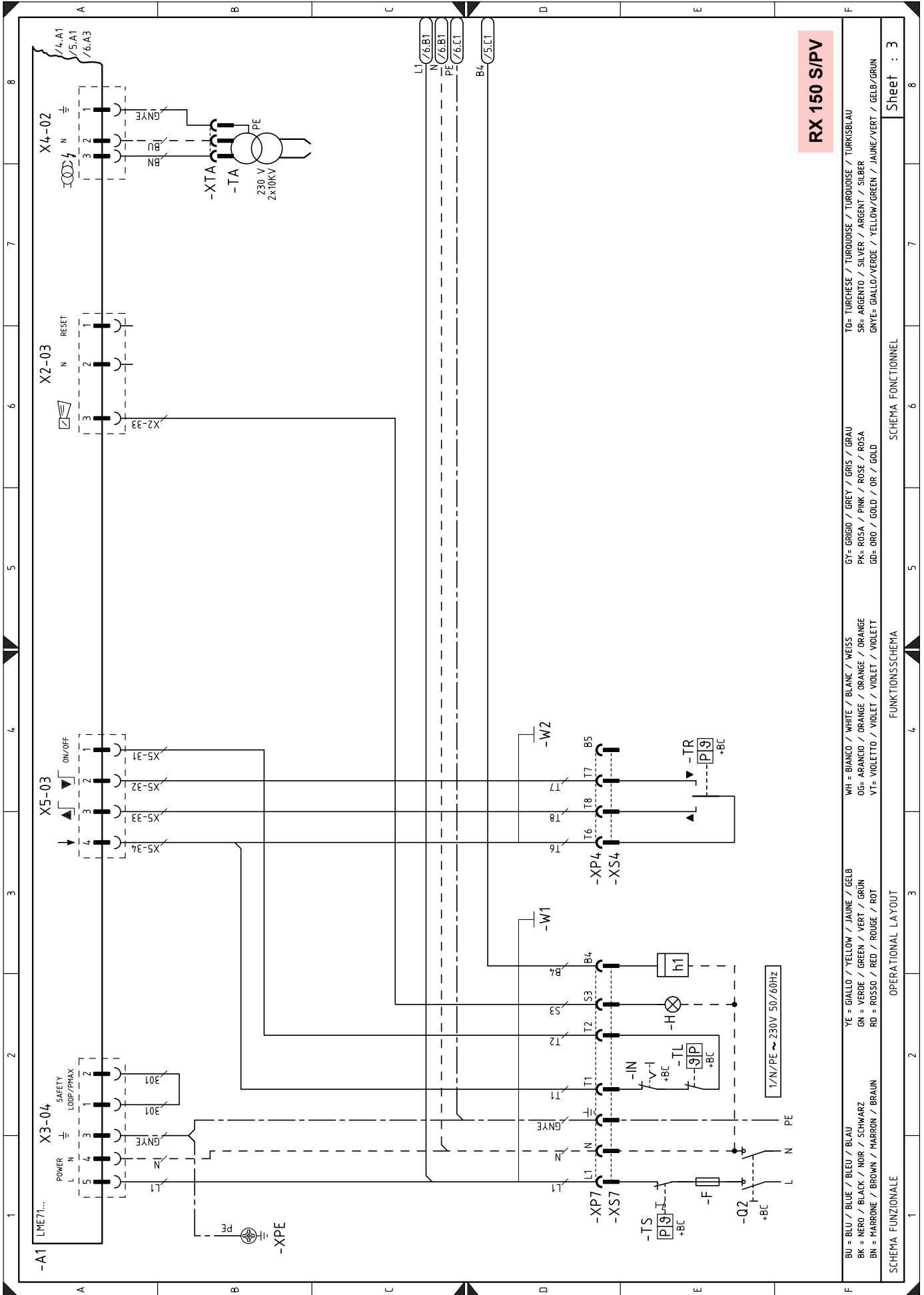

RX 150 S/PV

TO= TURCHESE / TURKOISE / TURKOISE / TURKISBLAU
 SR= ARGENTO / SILVER / ARGENT / SILBER
 GNYE= GIALLO/VERDE / YELLOW/GREEN / JAUNE/VERT / GELB/GRUN

GY= GRIGIO / GREY / GRIS / GRAU
 PK= ROSA / PINK / ROSE / ROSA
 GD= ORO / GOLD / OR / GOLD

WH = BIANCO / WHITE / BLANC / WEISS
 OG= ARANCIO / ORANGE / ORANGE / ORANGE
 VT= VIOLETT / VIOLET / VIOLET / VIOLETT

YE = GIALLO / YELLOW / JAUNE / GELB
 GN = VERDE / GREEN / VERT / GRUN
 RD = ROSSO / RED / ROUGE / ROT

BU = BLU / BLUE / BLEU / BLAU
 BK = NERO / BLACK / NOIR / SCHWARZ
 BN = MARRONE / BROWN / MARRON / BRAUN

SCHEMA FUNZIONALE

OPERATIONAL LAYOUT

FUNKTIONSSCHEMA

SCHEMA FONCTIONNEL

Sheet : 3

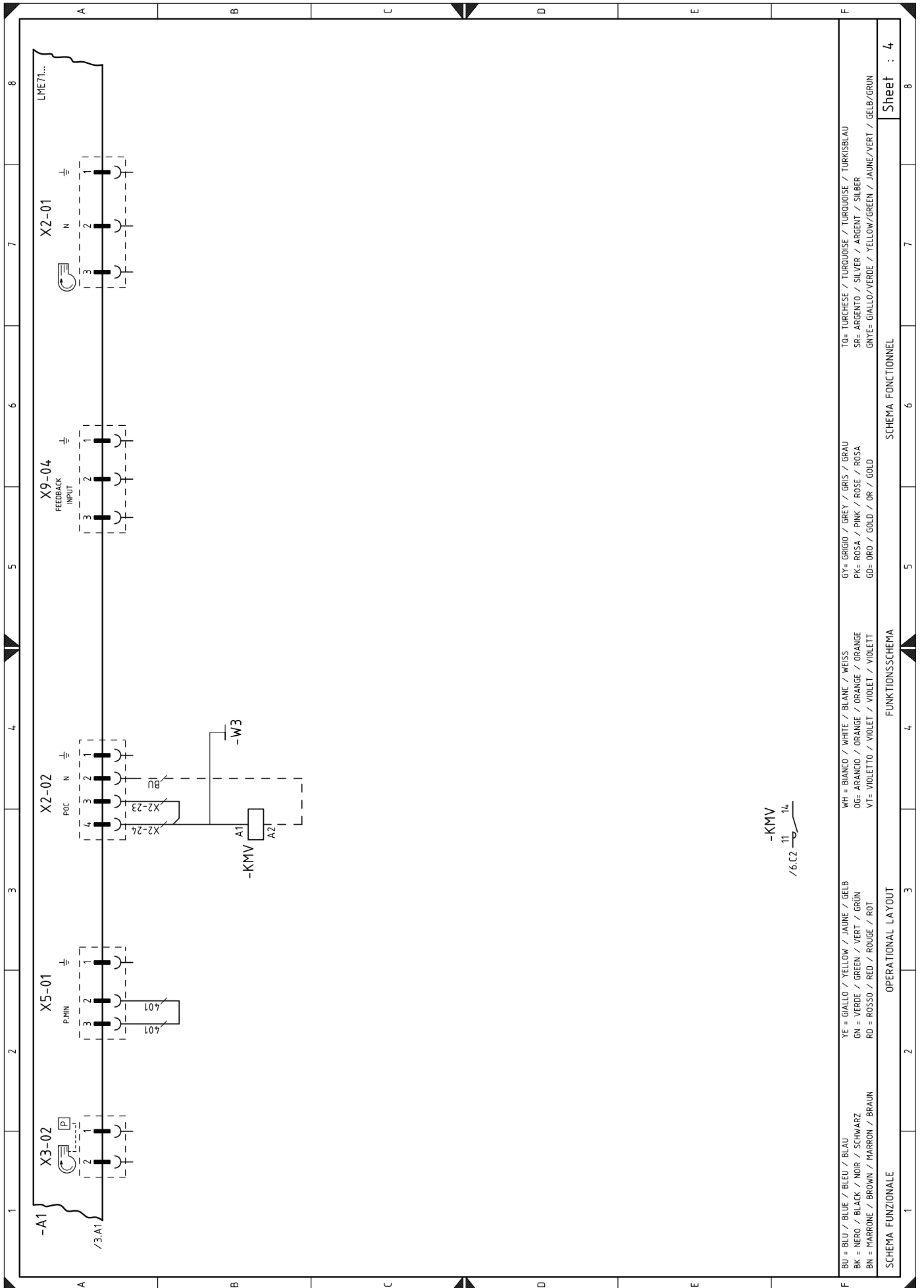

-KMV
/6.C2 11 14

BU = BLU / BLUE / BLEU / BLAU	YE = GIALLO / YELLOW / JAUNE / GELB	WH = BIANCO / WHITE / BLANC / WEISS	GY = GRIGIO / GREY / GRIS / GRAU	TQ = TURCHESE / TURQUOISE / TURKOUISE / TURKISBLAU
BK = NERO / BLACK / NOIR / SCHWARZ	GN = VERDE / GREEN / VERT / GRÜN	OG = ARANCIO / ORANGE / ORANGE / ORANGE	PK = ROSA / PINK / ROSE / ROSA	SR = ARGENTO / SILVER / ARGENT / SILBER
BN = MARRONE / BROWN / MARRON / BRAUN	RD = ROSSO / RED / ROUGE / ROT	VT = VIOLETTA / VIOLET / VIOLET / VIOLETT	GD = ORO / GOLD / OR / GOLD	GNYE = GIALLO/VERDE / YELLOW/GREEN / JAUNE/VERT / GELB/GRÜN

SCHEMA FUNZIONALE OPERATIONAL LAYOUT FUNKTIONSSCHEMA SCHEMA FONCTIONNEL

Sheet : 4

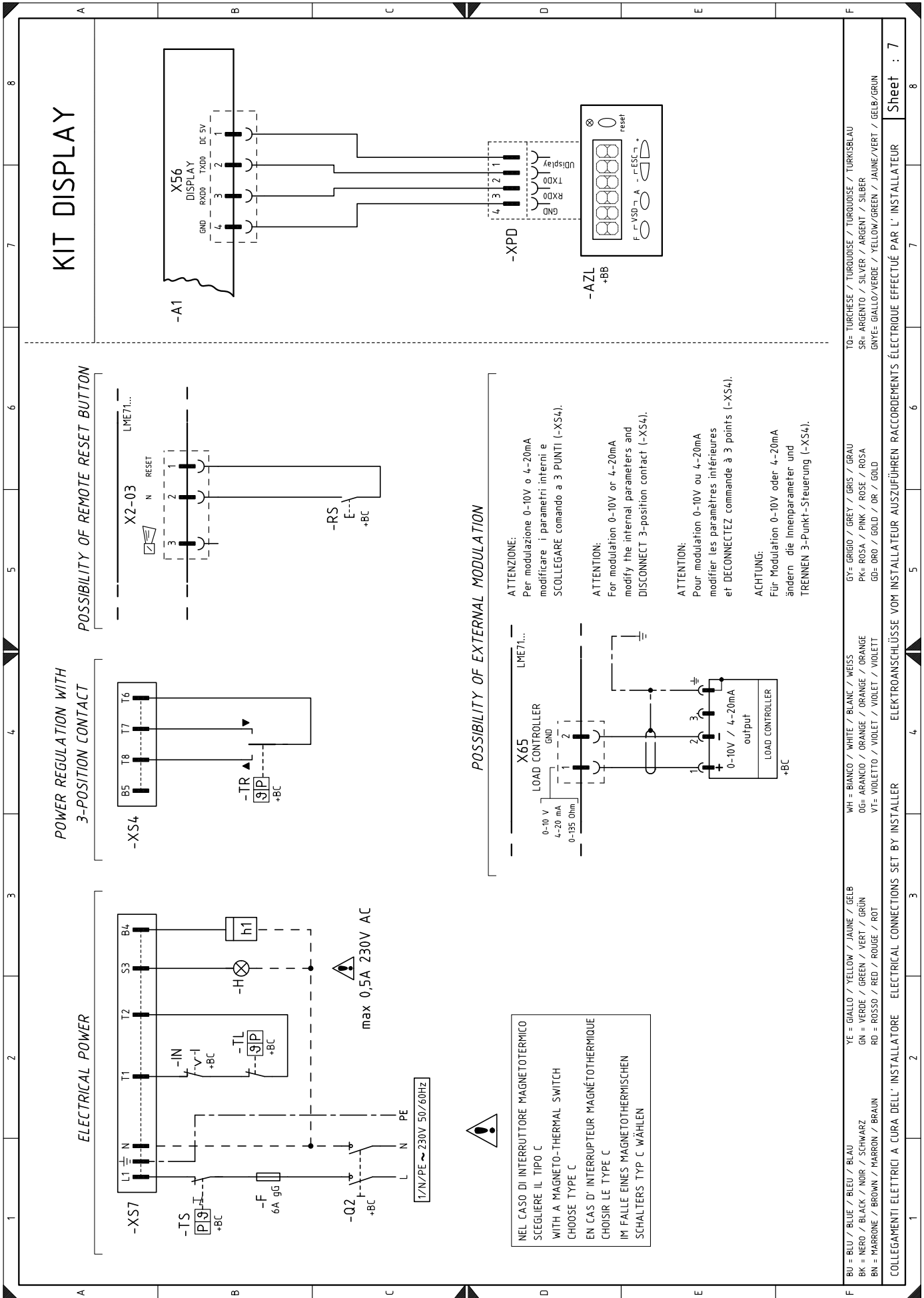

Wiring layout key

A1	Control box LME7...
AZL	Display for control box
+BB	Burners components
+BC	Boiler components
CN1	Ionisation probe connector
F	Fuse
H	External signalling of burner lockout
h1	Light signalling burner on
KMV	Fan motor contactor/relay
IN	Burner external "ON/OFF" switch
ION	Ionisation probe
MV	Fan motor
Q2	Auxiliary switches
RS	Burner external reset button
TA	Ignition transformer
TL	Limit thermostat/pressure switch
TR	Adjustment thermostat/pressure switch
TS	Safety thermostat/pressure switch
W...	Electric cables
X...	Control box connectors
XM...	Fan motor connectors
XPE	Main earth
XVY	Gas train connector
XP4	4 pole socket
XP7	7 pole socket
XS4	4-pin plug
XS7	7-pin plug
XTA	Ignition transformer connector
XTV	Fan earth
Y	Gas train



Импортер
в Республику Беларусь
8 (029) 11 915 11 INFO@SMARTFLAM.BY



Импортер
в Республику Беларусь
8 (029) 11 915 11 INFO@SMARTFLAM.BY

RIELLO

RIELLO S.p.A.
I-37045 Legnago (VR)
Tel.: +39.0442.630111
[http:// www.riello.it](http://www.riello.it)
[http:// www.riello.com](http://www.riello.com)